

**Template Drawings on Top Views  
Shown for Reference Only**

**REMARKS:**

- > Arrows toward unit show RETURN option.
- > Arrows away from unit show SUPPLY option.
- > Water Inlet / Outlet = 3/4" MPT.
- > Condensate Drain = 3/4" ID Hose.
- > 2 Disposable Filter Included (16"H X 20"W X 1"T)
- > 18" long Supply, Return and Condensate Hose Included
- > Total Weight: 638 lbs  
(Includes Cabinet, Chassis, Panel, Boot and ERV)

- (A) - 20" x 10" KnockOut for Top Supply Ducting
- (B) - Electrical Box KnockOut for Electrical Connections  
Box Size (4"H X 4"W X 2-1/4"D)
- (C) - KnockOut For Flex. Hose Connection of Risers to Chassis or  
for Return Air

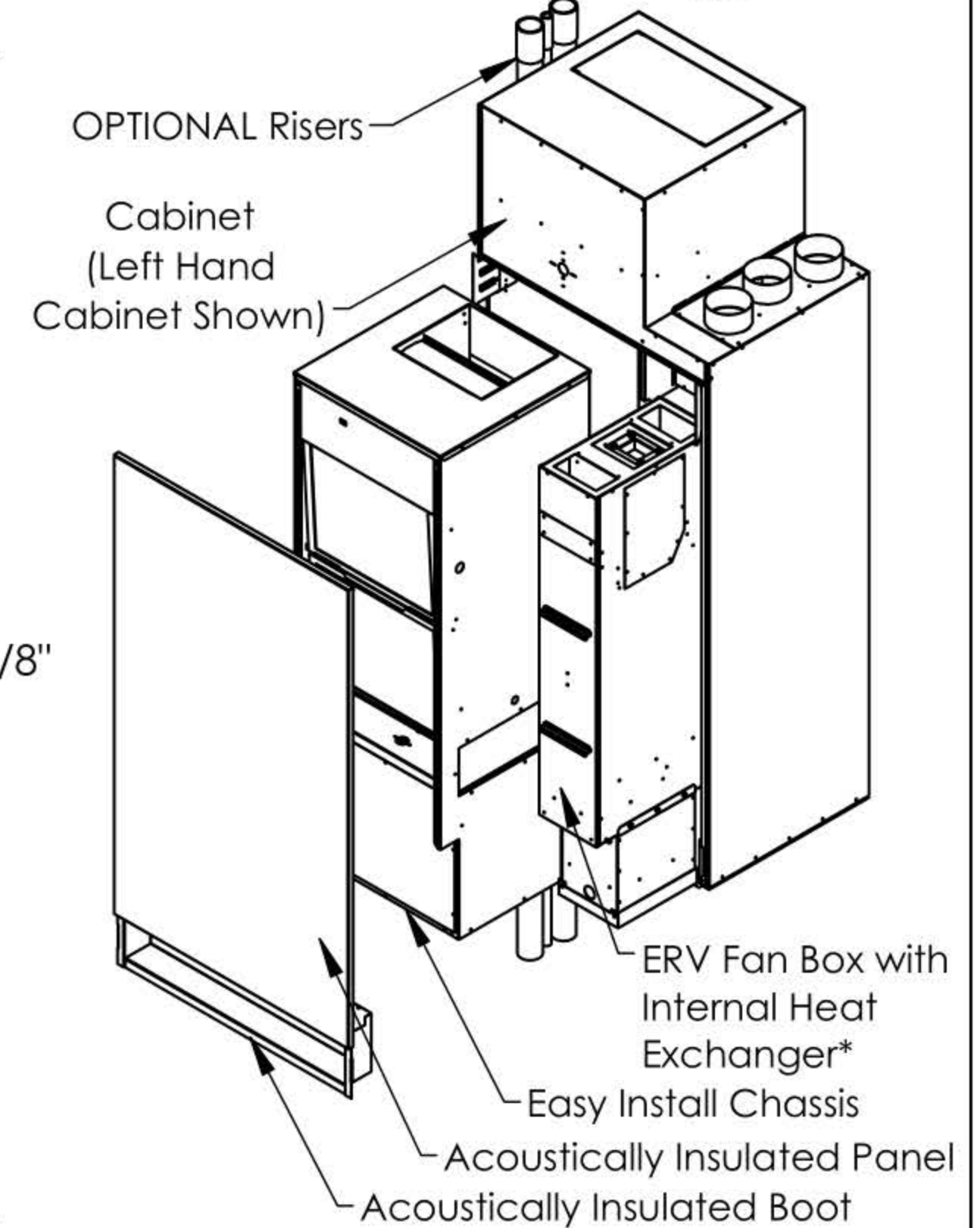
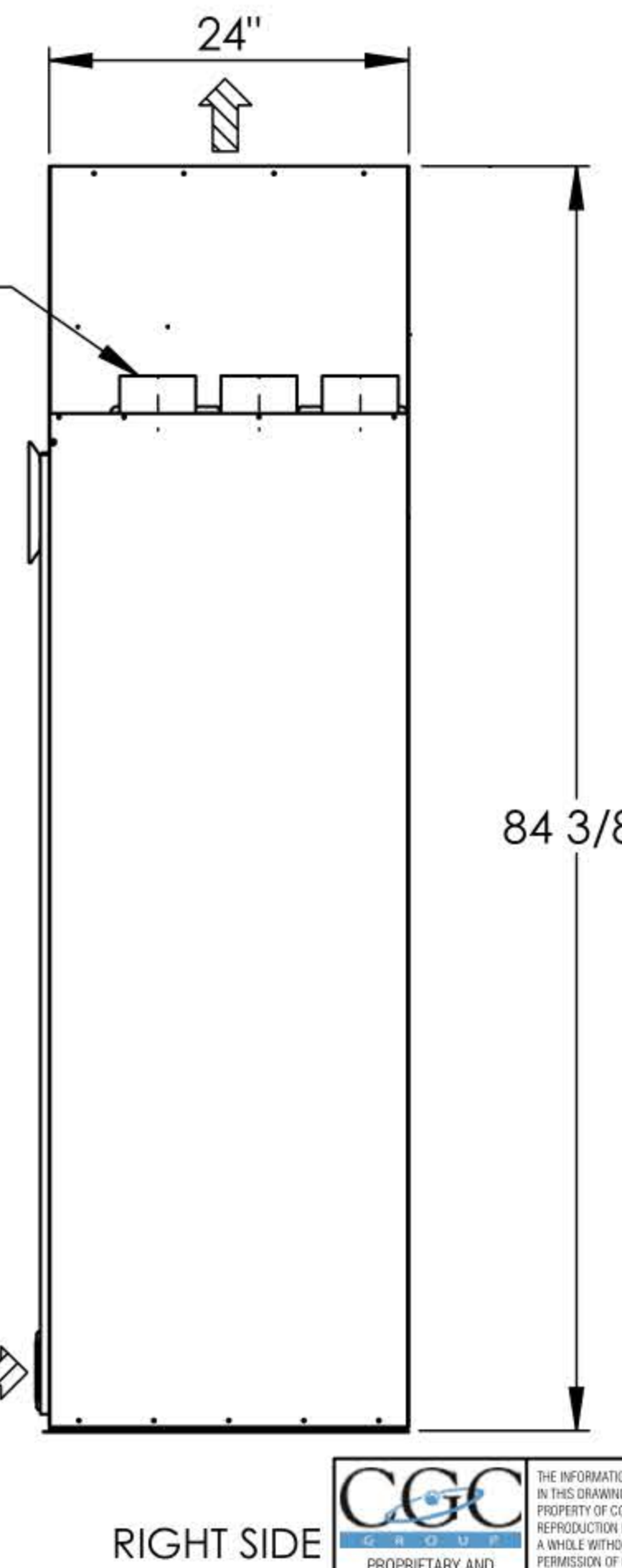
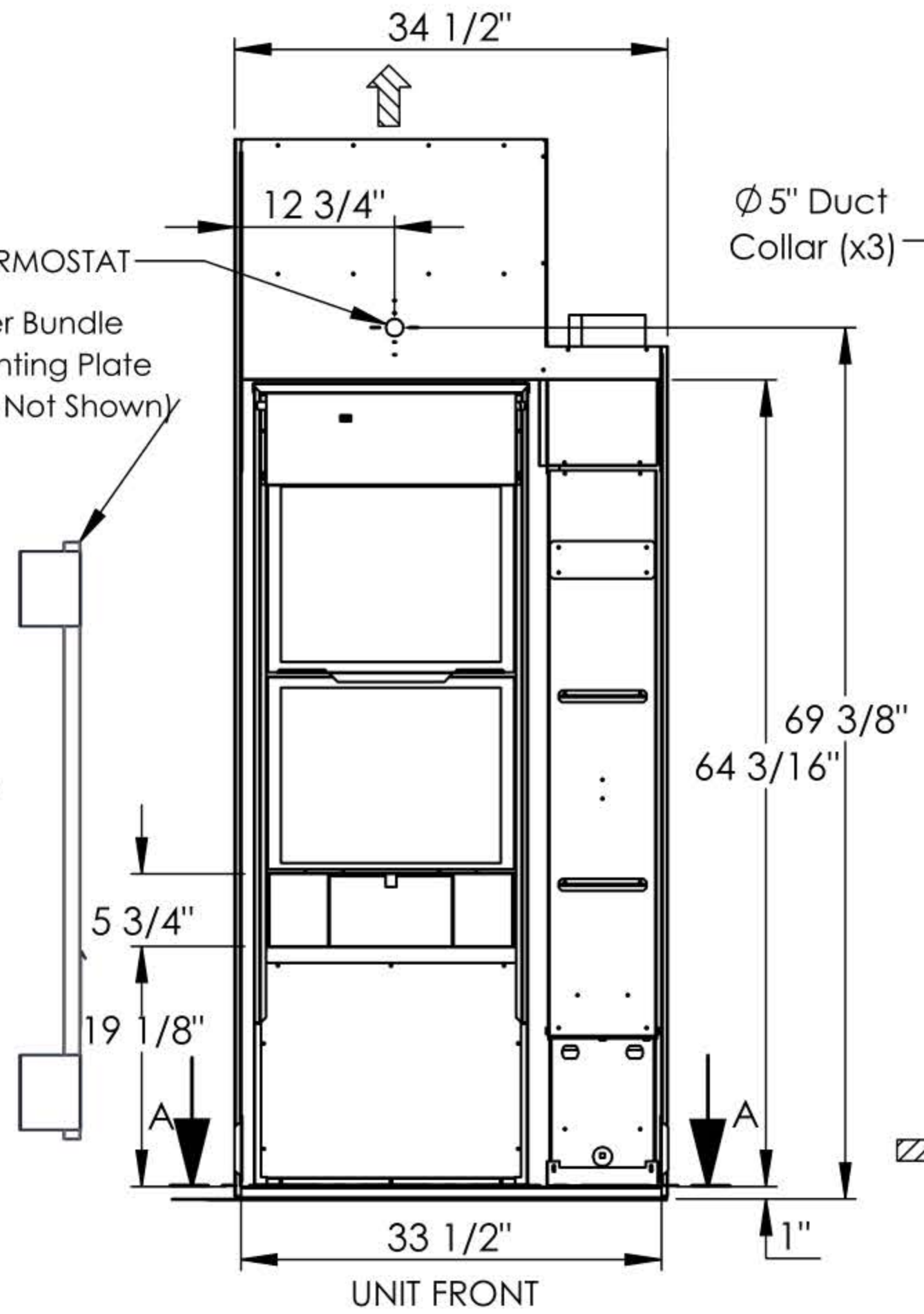
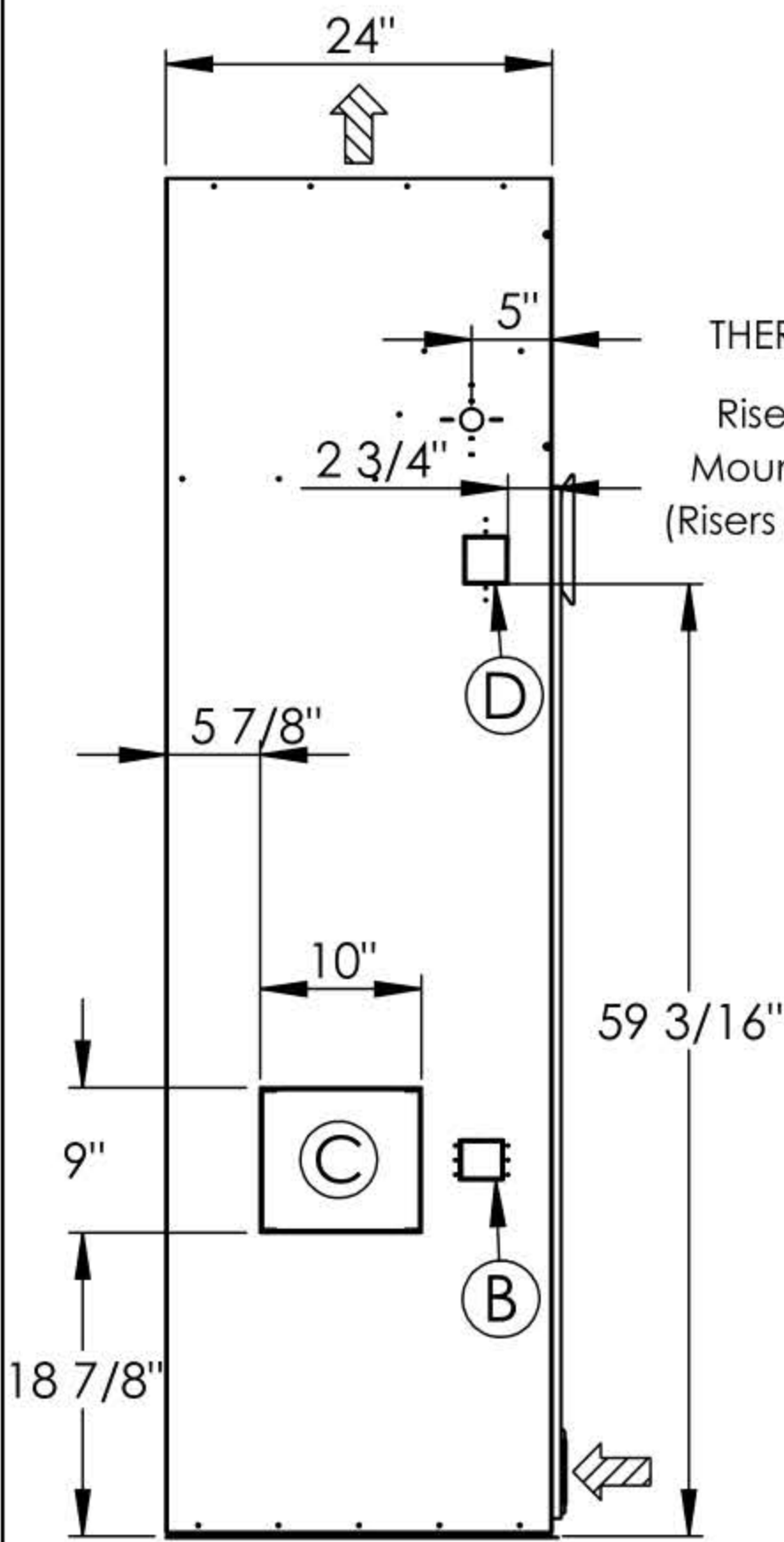
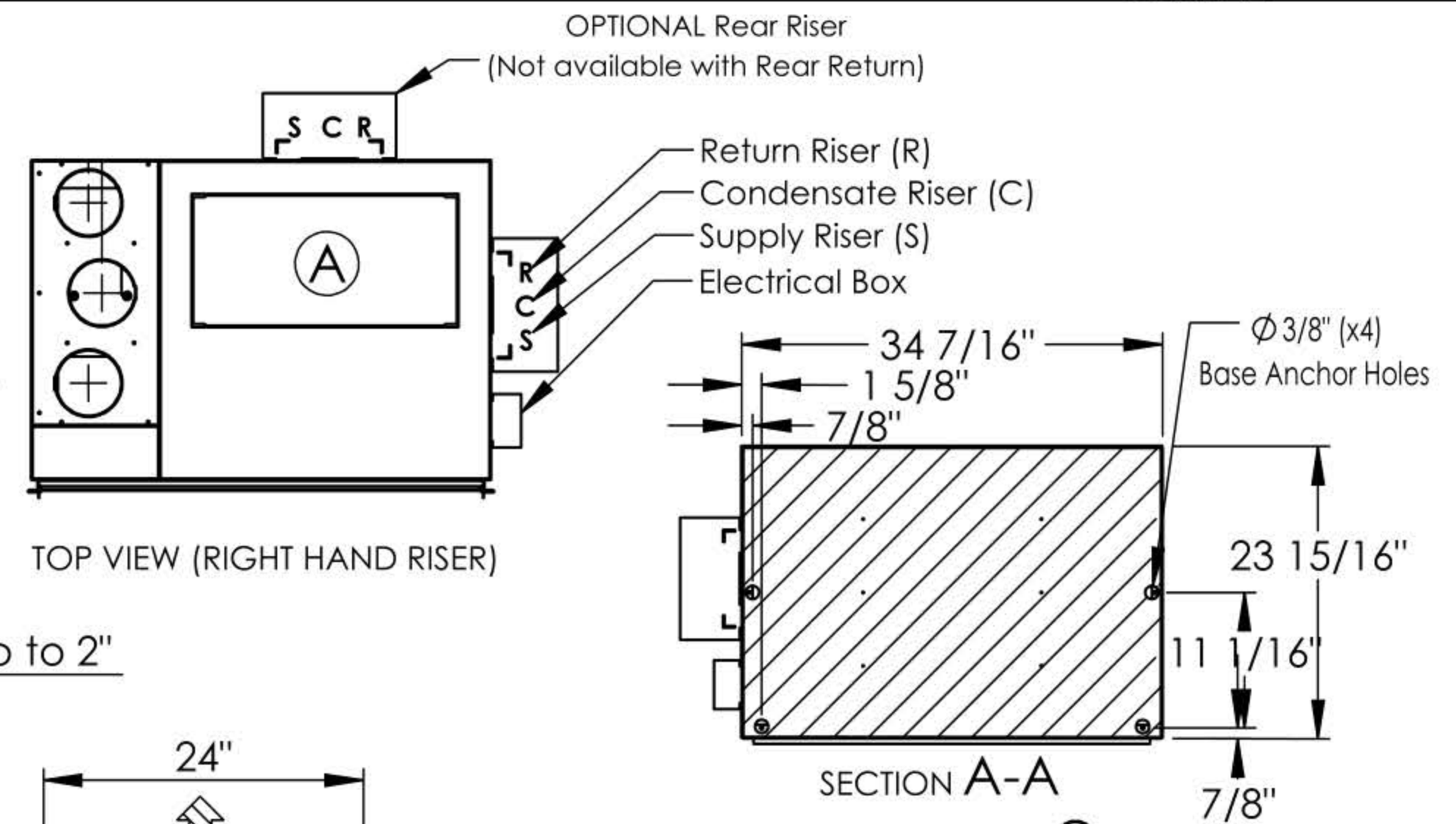
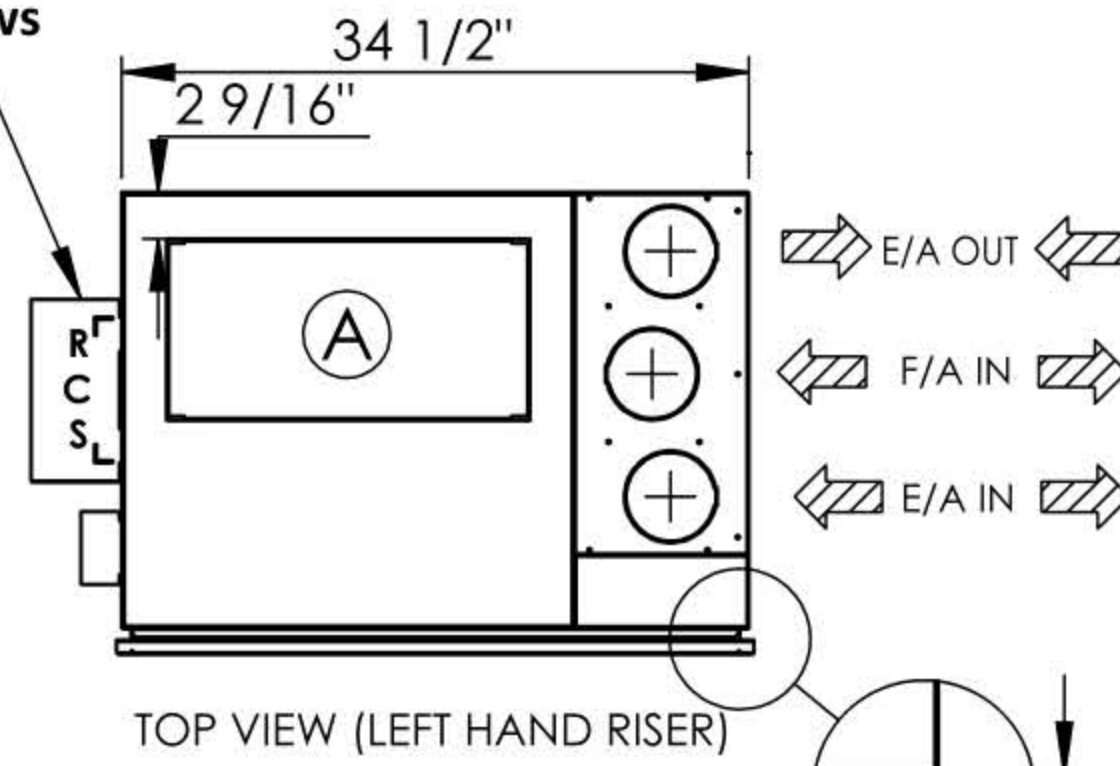

<p>PROPRIETARY AND CONFIDENTIAL</p> <p>UNLESS OTHERWISE SPECIFIED: DIMENSIONS ARE IN INCHES</p> <p>TOLERANCES UNLESS OTHERWISE NOTED ARE:</p> <table border="0"> <tr><td>FRACTIONAL</td><td>± 1/16"</td></tr> <tr><td>ANGULAR</td><td>± 0.5°</td></tr> <tr><td>2X</td><td>± .1°</td></tr> <tr><td>30X</td><td>± .06°</td></tr> <tr><td>.XXX</td><td>± .002"</td></tr> <tr><td>.XXXX</td><td>± .0005"</td></tr> </table>	FRACTIONAL	± 1/16"	ANGULAR	± 0.5°	2X	± .1°	30X	± .06°	.XXX	± .002"	.XXXX	± .0005"	<p>THE INFORMATION CONTAINED IN THIS DRAWING IS THE SOLE PROPERTY OF CGC Group. ANY REPRODUCTION IN PART OR AS A WHOLE WITHOUT THE WRITTEN PERMISSION OF CGC Group IS PROHIBITED.</p>	<p>NAME: AAR</p> <p>DATE: 12/16/2020</p>	<p>PROJECT: Homekeeper 2 ERV Cabinet</p>
	FRACTIONAL	± 1/16"													
ANGULAR	± 0.5°														
2X	± .1°														
30X	± .06°														
.XXX	± .002"														
.XXXX	± .0005"														
<p>DRAWN: AAR</p> <p>CHECKED:</p> <p>MATERIAL:</p> <p>FINISH:</p>	<p>TITLE: Bulldog HKV036-048 ERV Cabinet Dimensional Data HKEC2</p>	<p>SIZE: A</p> <p>DWG. NO.: HKV2_ERV_DD</p>	<p>REV.: B</p>												