



Installation Operation Maintenance Manual

Vertical Stacked Units
(Cabinet with ERV)



InnKeeper/HomeKeeper

Models: IKV 008-018 IEV 008-012

 HKV 016-036 HEV 016-036

www.bulldogheatpump.com

Table of Contents

Information	3
Handling	3
Storage	3
Model Nomenclature	4
Weight/Dimension/Clearance	5
Unit Installation	6
General Installation Checklist	6
Location	6
Cabinet Placement	7
Riser Bundle Installation (When Ordered)	8
Electrical Wiring	10
Dry walling	11
ERV Installation	12
General Installation Checklist	12
Location & Placement	12
Unit Operation – In Suite	13
ERV Operation	15
ERV Field Reversing	16
Operation – Detailed	17
Commission & Start Up	22
Maintenance	25
Details	26
InnKeeper ERV Detail Drawing	26
HomeKeeper ERV Detail Drawing	27
Generic Wiring Diagram for IKV008-018 Units	28
Generic Wiring Diagram for HKV016-036 Units	29
InnKeeper ERV Template	30
HomeKeeper ERV Template	31
Diagnosis Table	32

INFORMATION

Handling

Care must be taken in handling the cabinet, chassis, risers, ERV and other accessories to ensure that this equipment does not sustain any damage. It is recommended that the chassis, ERV and cabinet be transported individually on a two-wheel cart.

The protective shipping packaging should remain on the chassis, ERV, and cabinet until they are ready for installation. During construction, the unit must not be run and shall be sheltered from contaminants and debris such as drywall dust, wood chips, and paint that could damage the fan or block the cooling/heating coil which may result in diminished performance.

Storage

The cabinet should be stored upside down to prevent damaging the foam gaskets on the underside of the cabinet. The cabinet, risers, chassis and ERV's should be stored in a non-corrosive environment sheltered from conditions of extreme temperature or humidity. Subjecting the unit, and risers to conditions of this nature may result in significantly reduced performance, reliability, and operational life.

The chassis must be stored in an upright position at all times with the compressor section towards the ground and the fan section oriented upwards.

Failure to maintain the chassis in an upright position may result in permanent damage to the unit. Dropping the chassis or exposing it to extreme shock or vibration may also result in permanent damage to the interior components and piping.

Dropping the ERV or exposing it to extreme shock or vibration may also result in permanent damage to the interior components of the unit.

The unit is intended for interior use only and should be stored indoors at all times to protect it from the elements and to help eliminate the potential growth of indoor air quality (IAQ) contaminants.

If indoor storage is not possible, the equipment may be stored outdoors during the summer months only, if the following provisions are met:

1. The equipment must be placed on a dry surface, or raised off the ground in a manner which allows for air-circulation beneath the unit.
2. A waterproof tarp must be used to cover the equipment in order to provide protection from the elements.
Continuous ventilation to the units must be provided to help prevent moisture accumulation on the interior and exterior surfaces. Moisture buildup on, or within the unit's insulation may result.
3. The chassis and ERV units must be stored in their original packaging.
4. The individual units shall not be stacked on top of one another.
If the unit was previously in use, ensure that all water in the coil has been blown out and that all hose connections are plugged during storage.

Model Nomenclature

CHASSIS NOMENCLATURE						
Model	Nom. Capacity (x1000 BTU/h)	Electrical Supply (V - Ph - Hz)	Refrigerant	Version	Options	Common Options ⁽⁵⁾
IKV (InnKeeper)	008	A: 115-1-60 (IKV008, IKV010 & IKV012 only)	4: R410a	010: for IKV units, HKV016 & HKV036 020: for HKV030 030: for HKV020 & HKV024	S: Standard Unit X: Options Required A: Custom Options	(21) Condensate Overflow Sensor (24) Mounting 3 rd party controller (27) Alarm notification (28) Remote Shutdown (41) Demand flow w/ auto flow valve (42) Auto Flow Valve (44) Cooling Only unit (54D/C) Dehumidification control (61) ECM ⁽²⁾ (68.1) 1" MERV 7 Filter (71) Integrated ERV Core ⁽³⁾
	010					
	012					
	015 ⁽⁴⁾	B: 208/230 - 1 - 60				
	018 ⁽⁴⁾	D: 277 - 1 - 60				
HKV (HomeKeeper)	016	G: 240 - 1 - 60				
	020					
	024					
	030					
036						

CABINET		
Model	Cabinet Type	Common Options ⁽⁵⁾
IK (InnKeeper Cabinet)	C-0: Universal Cabinet	(5) LEED Packaging
HK (HomeKeeper Cabinet)	E-1: Integrated ERV Cabinet (with Right Hand ERV) E-2: Integrated ERV Cabinet (with Left Hand ERV)	(86) Electrical Receptacle (90.X) Base Extension ⁽⁴⁾

RETURN AIR PANEL		
Model	RA Panel Type	Arrangement
IK (InnKeeper RA Panel)	U: Panel for Universal Cabinet	-0: Slip Lock Panel (no hinges)
HK (HomeKeeper RA Panel)	EP: Panel for Integrated ERV Cabinet	-1: Hinges are on the left -2: Hinges are on the right
		(84) Locking Hinged Return Air Panel ⁽⁴⁾ (92) Two piece Return Air Panel (93) Three piece Return Air Panel

Notes:

- (1) IKV015 & IKV018 are only available in PSC motors
- (2) HomeKeeper units come with constant torque EC motor as standard
- (3) When ERV is selected, larger cabinet is required
- (4) Minimum 2" base extension is required for Hinged Return Air Panels



Refrigerant Charge

Unit Model	IKV 008	IKV 010	IKV 012	IKV 015	IKV 018	HKV 016	HKV 020	HKV 024	HKV 030	HKV 036	HKV 042	HKV 048
R410A Charge (oz.)	27	28	30	35	45	32	35	40	45	50	60	60

Weight/Dimension/Clearance

Physical Details	Physical Details	InnKeeper IKV008 IKV010 1KV012 IKV015 IKV018	HomeKeeper HKV016 HKV020 HKV024 HKV030 HKV036
Integrated ERV Cabinet w/ Standard RA Panel	Dimensions L x W x H Weight, lbs. (kg)	14" x 27" x 84" (355 x 686 x 2,133mm) 150 (68)	20" x 29.5" x 84" (508 x 749 x 2,133mm) 175 (80)
Chassis	Dimensions L x W x H Weight, lbs. (kg)	13" x 16" x 48" (330 x 406 x 1,219mm) 125 (57) 125 (57) 125 (57) 150 (68) 150 (68)	18" x 18" x 57" (457 x 457 x 1,448mm) 180 (82) 180 (82) 180 (82) 180 (82) 180 (82)
ERV	Dimensions L x W x H Weight, lbs. (kg)	9" x 13" x 48" (228 x 330 x 1,219mm) 60 (27)	9" x 18" x 57" (228 x 457 x 1,448mm) 80 (36)

Refer to Detail Drawings on pages 26-27.

Unit Clearance:

The vertical stacked product has a sound-dampening front cover panel. The sound-dampening panel slides off with minimal service clearance, however, in the event of chassis replacement the front service entrance must permit straight horizontal removal of the chassis. The return air path must be unobstructed during operation.

The installation of all vertical stacked product and components and accessories must be in accordance with all local code and regulations of all governing authorities having jurisdiction. The manufacturer recommends the following installation procedures.

It is the responsibility of the installing contractor to comply with all applicable codes and regulations. It is the responsibility of the installing contractor to ensure adequate service clearance for regular maintenance or for repair in place is exercised. The installing contractor will be responsible for removing the unit if it is not serviceable in place.

UNIT INSTALLATION

The information below details the correct installation procedure for a vertical stacked unit with ERV. Please read this document in its entirety prior to proceeding with unit installation. Specific site conditions may warrant variations in locations and dimensions.

General Installation Checklist

1. Remove packaging and inspect the unit. Carefully check for shipping damage or material shortage; file a freight claim and notify appropriate sales representative if damage is found.
NOTE: The chassis, ERV, and front panel are separate from the cabinet and risers.
2. Verify the correct model and voltage as indicated by the model number.
3. Verify the installation location of the unit using the sheet metal template that is provided.
4. Verify that the power supply complies with the nameplate specification.
5. Connect properly sized and protected power supply wiring to the electrical receptacle by others in the cabinet.
6. Install proper grounding wires to an earth ground on the cabinet as well as the receptacle.

Location

Determine cabinet location using manufacturer supplied template. Refer to InnKeeper & HomeKeeper ERV template drawings (Pages 28-29)

1. Locate core holes for risers using supplied template.
2. Locate unit in an indoor area. The ambient temperature surrounding the unit must not be less than 45°F (7°C). Do not locate the unit in areas that may be subjected to freezing temperatures.



Please note: The F/A in and E/A out are field reversible

Figure 1

Cabinet Placement

1. Review riser schedule to identify cabinet type and location.
2. Position the cabinet. Shim to cabinet level, then anchor the cabinet with concrete bolts to floor (see **Figure 2**).

If installing a base extension, bolt the extension to the concrete floor (see **Figure 3**).

3. The riser knockout to be left exposed for riser installation.

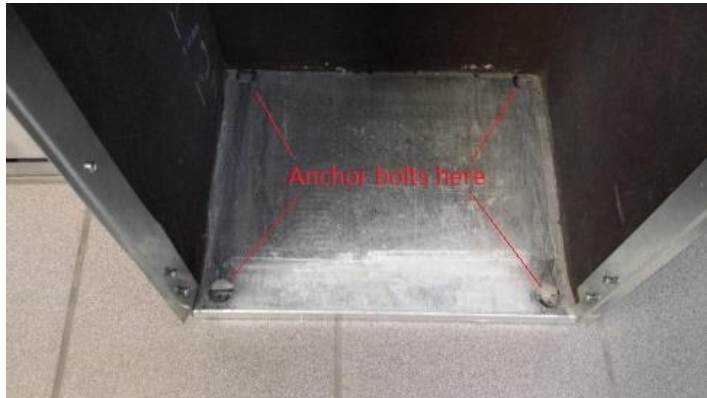

Figure 2



Figure 3

Riser Bundle Installation (When Ordered)

1. The supply and return risers are standard type “M” copper. Type “L” copper is optional. The condensate riser is a type “M” copper.
2. Risers are factory swaged expanded top end to accept riser from the unit above to minimize field brazing. The factory will also pre-install service isolation ball valves on the supply and return risers.
3. The risers are pre-bundled with a metal channel and cabinet with neoprene isolation to prevent metal-to-metal contact with housing.
4. Match unit location with riser bundle nomenclature as, indicated by the manufacturer supplied riser schedule, and the label affixed to the riser bundle.
5. Refer to **Figure 6 (pg. 9)** for positioning of risers pertaining to floor-to-floor installment. The riser diameter shall be shown on plans. Riser length and schedule shall be coordinated with the mechanical contractor.
6. Hang the rider bundle slip fit connection onto the riser Knockout on the cabinet, see **Figure 4**.
7. Align and insert riser into swage top end of the risers below. Do not scrape or dent the risers during positioning.
8. The risers’ bottom ends should
9. slide approximately 2” of the 3” swage top ends. This will allow for the floor-to-floor variations and prevent the riser joints from bottoming out.
10. Expansion allowance is not needed as the difference between the Summer to Winter temperature change is minimal.
11. Braze riser joints with Sil-Fos or 95/5 tin antimony solder. Perform a system leak test.
12. A fire stop may be required for the riser openings in the floors. Consult local fire codes for dictation on appropriate requirements.

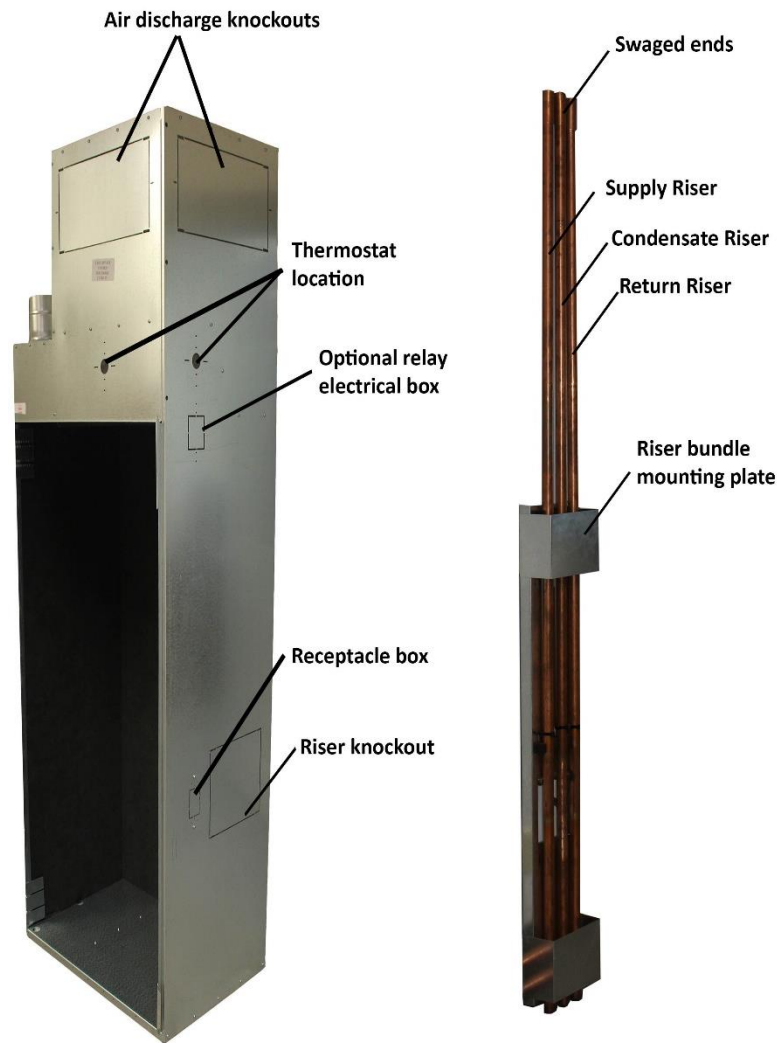

Figure 4



Figure 5

Riser Drawing

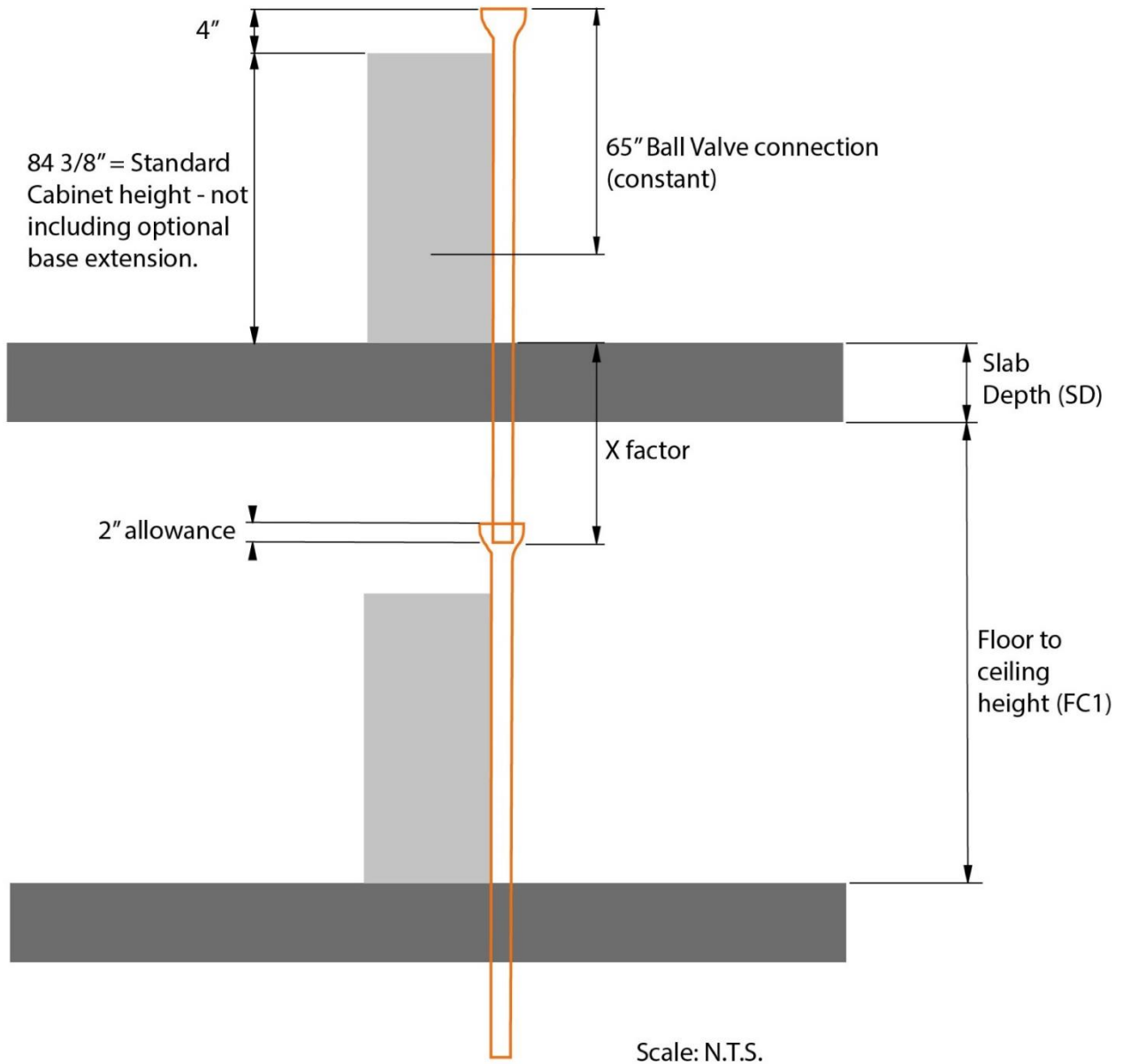





Figure 6

Electrical Wiring

Main Wiring

Electrical connections are made to the cabinet. Cabinets have knockouts for a standard single gang electrical box. Receptacle may be included with unit if ordered. Box must not protrude into cabinet more than ½” or it will interfere with the chassis installation or removal.

Receptacles required to match factory supplied cord are as follows.

Current (A)	Models	Phase	NEMA Configuration	Voltage (V)	Part #	Configuration
15	IKV008- IKV018	1	6-15R	208-230	PWR-0401	
20	HKV016- HKV024	1	6-20R	208-230	PWR-0402	
25-30	HKV030- HKV036	1	L6-30R	208-230	PWR-0404	

Note: Ensure that the ground wire is fastened to the cabinet **and** receptacle.

Control Wiring:

The BULLDOG Heat Pump does not have a reversing valve. The compressor is **OFF** in heating use. **DO NOT** use Heat Pump configuration on thermostats. Set thermostat to Gas or ELC.

See **Figure 8** for Standard Control wiring of a single stage heat, single stage cool thermostat wiring.

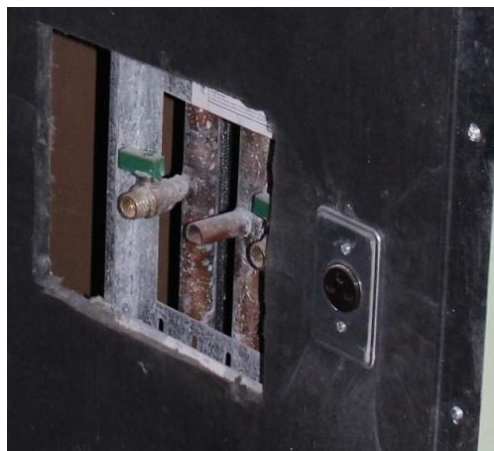

Figure 7

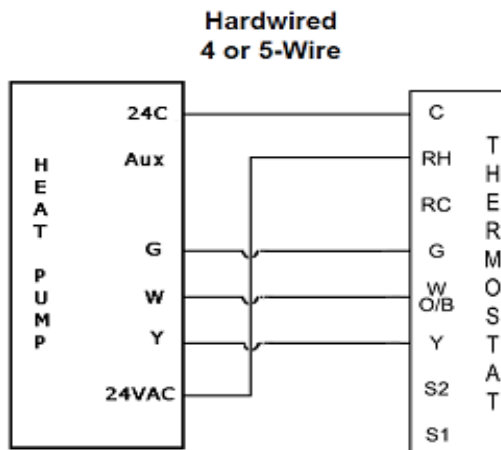
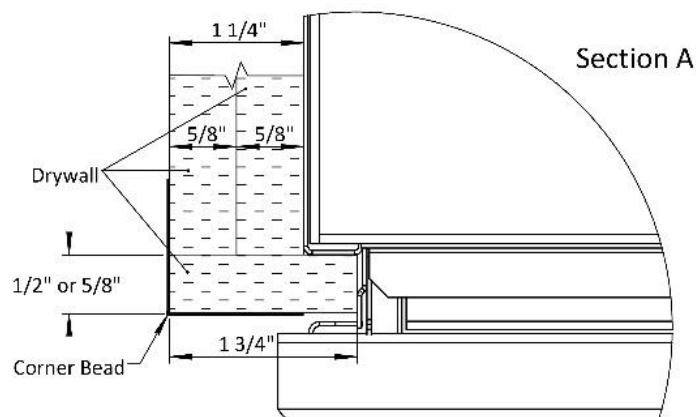
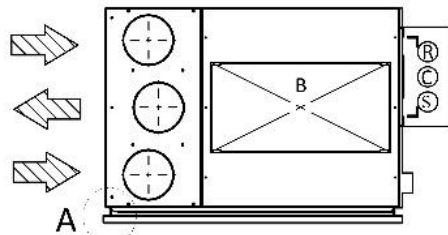

Figure 8

Dry Walling

1. Attach drywall to front of unit to ensure the proper fit of acoustic panel as shown in **Figure 9**.
2. Glue or attach drywall with screws to the front of cabinet.
3. It is permissible to glue or screw drywall directly to the side of the cabinet as long as the riser bundle is not on that side. Please note that the drywall screw must not be longer than the drywall thickness plus a maximum 3/8".
4. Use studs to frame in the riser side of the cabinet where necessary. Keep screws away from the riser pipes.
5. Mount thermostat and connect to the thermostat wire. Ensure that the thermostat is not mounted in direct sunlight, or within the supply airstream of the heat pump unit.
6. Wire thermostat to control board. Connect power cord at cabinet electrical box.



Arrangement of Drywall Required to Make Flush with Cabinet.
To Be Done on ERV Side.
(Can Also be Completed Through the Use of Steel Studs)

Figure 9

ERV INSTALLATION

General Installation Checklist

1. Remove packaging and inspect the ERV. Carefully check for shipping damage or material shortage; file a freight claim and notify your sales representative if damage or deficiency is found.
2. Verify the model.
3. Verify that the power supply complies with the nameplate specification.
4. Verify the installation location of the ERV.

Location and Placement

1. Slide ERV into place and review that the ERV is securely in place.
2. Connect power through the 4 pin Molex connection between the ERV and Chassis.
3. Connect signal through 9 pin Molex connection between ERV and chassis – **See Figure 10.**

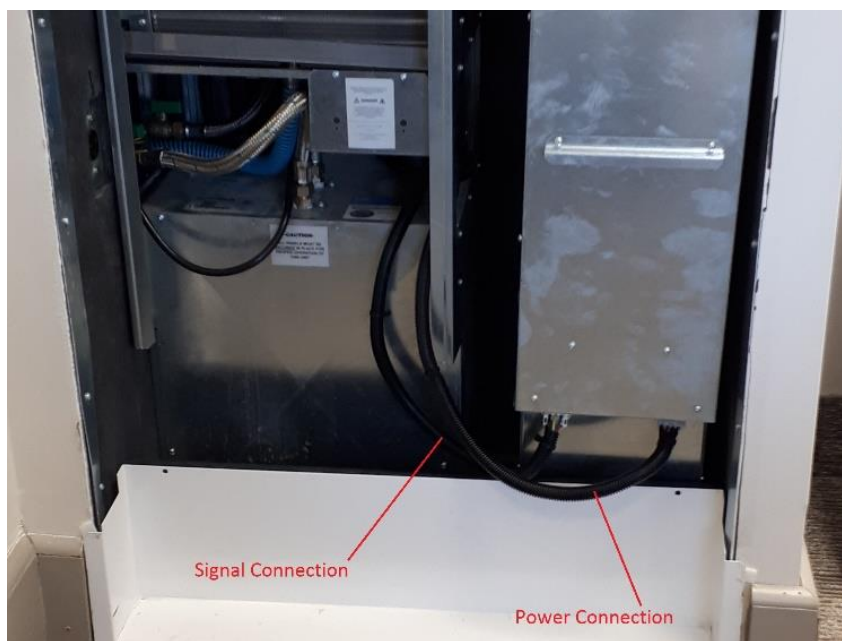

Figure 10

UNIT OPERATION – IN SUITE

CAUTION:

To avoid fouled machinery, extensive unit clean up, and void warranty, do not operate units without air filters in place, and do not operate units during the construction process.

The BULLDOG Heat Pump provides year round cooling and heating controlled by your in-suite wall mounted thermostat.

The BULLDOG Heat Pump provides DX cooling with a water-cooled refrigeration circuit, and hydronic heating with a hot water coil. The compressor operates in the cooling mode only and shuts down during the heating mode, providing for quieter operation, extended compressor life, and a reduction in energy consumption.

To ensure correct operation, centralized equipment located within the building mechanical room is automatically controlled to provide each heat pump unit with water that is at the proper temperature and flow rate.

Fan Operation:

Each heat pump has two-speed fan operation. The fan operates as follows:

- LOW Speed
 - First stage of heating mode (Thermostat Setting: Fan Automatic)
 - Fan only operation (Thermostat Setting: Fan On)

- HIGH Speed
 - The second stage of heating mode
 - Cooling mode

Standard Heating Operation:

Each heat pump has two stages of heat operation. The compressor does not operate in either stage. To enable heating operation, Manual Change Over thermostats (MCO) must be set to “Heat” mode. Automatic Change Over (ACO) thermostats should be set to “Auto” or heat mode. To start heating operation, the suite temperature must fall below the heat set-point temperature.

The thermostat will automatically stop heating operation once the space temperature rises up to the heat set-point temperature.

Stage 1 Heating: Fan operates at low speed for 10 minutes with minimal noise in an attempt to elevate suite temperature to desired level.

Stage 2 Heating: After 10 minutes, if set-point temperature is not reached, fan will automatically step up and operate at high speed.



Cooling Operation:

Each heat pump has a water cooled refrigeration circuit that operates only during the cooling mode.

To enable cooling operation, MCO thermostats must be set to “Cool” mode. The ACO thermostats should be set to “Auto” or cool mode. In order for the cooling operation to become activated, the suite temperature must rise above the cool set-point temperature.

The thermostat will automatically stop cooling once the space temperature drops below the cool set-point temperature.

Cooling: The fan always operates at high speed during the cooling operation.
The compressor also operates during the cooling operation.

Time Delays:

- Thermostat time delay up to 5 minutes upon initial power up.
- Thermostat time delay up to 5 minutes when switching between heat/cool/off modes.
- Heat pump time delay up to 5 minutes upon initial startup.
- Heat pump time delay up to 5 minutes from the end of a cooling operation to the start of the next cooling operation.

Recommendations:

1. Set the thermostat fan to ON for continuous fan operation while your suite is occupied. This will help to ensure that the temperature is uniform throughout the suite.
2. In order to provide space conditioning while you are away, keep the thermostat system switch in the appropriate heat or cool mode. The heat pump will not heat or cool if the thermostat system switch is set to the “OFF” position.
3. When away for a short duration, set the thermostat as follows:
 - a. Set fan to AUTO
 - b. Set thermostat to appropriate heat or cool mode (based on seasonal conditions).
 - c. Set heat or cool set-point to your desired suite temperature (ie. 72°F or 22°C).
4. When away for an extended period, set the thermostat as follows:
 - a. Set fan to AUTO
 - b. Set thermostat to appropriate heat or cool mode (based on seasonal conditions).
 - c. During cooler seasons set your thermostat to a minimum set point of 65°F (18°C)
 - d. During warmer seasons set your thermostat to a maximum set point of 78°F (26°C)
5. It is recommended that you maintain the same set points throughout the day regardless if you are in your suite or not. This provides maximum comfort for occupants. If you must adjust the set-point during the night or during away periods in the day it is recommended that heating setback be limited to 2 degrees and cooling to 4 degrees. This will help to ensure the unit operates minimally; preventing your suite from becoming excessively cold or hot.

ERV OPERATION

ERV Fans:

Recovery mode shall be selectable and shall be enabled only when the unit main supply fan is in operation. The recovery module shall incorporate an exhaust air fan and an outside air fan. The fans shall be provided with high efficiency external rotor motors.

InnKeepers (IK008 to IK 018)

Outside air fan shall be designed to provide 50 CFM (24 l/s) of outside air against an external static pressure of .15" (37 Pa) and the exhaust air fan shall exhaust 50 CFM (24 l/s) against a static pressure of 0.25" (62 Pa).

HomeKeepers (HK016 to HK 036)

Outside air fan shall be designed to provide 100 CFM (47 l/s) of outside air against an external static pressure of 0.15" (37 Pa) and the exhaust air fan shall exhaust 100 CFM (47 l/s) against a static pressure of 0.25" (62 Pa).

The exhaust and supply fans speed can be changed by rotating the knob located at the front of ERV using a 9/16" nut driver. See **Figure 11**.



Figure 11

Core Media:

Fan and Core sections shall be removable.

The ERV membrane is constructed from a composite of polymer materials that allows heat and water vapor to transfer from one air stream to another while preventing the cross-over of gases and contaminants such as Volatile Organic Compounds (VOC's), carbon dioxide, stale air, methane, and odors. The membrane contains Microban anti-microbial protection which will eliminate mold and bacteria that reach this surface. The sensible efficiency shall be no less than 70%.

Defrost:

The outside air fan shall be turned off during the defrost cycle. The defrost cycle shall be temperature dependent and shall be activated with a drop in fresh air temperature below 34°F. The warm air exhaust will melt the frost build up and the fresh air fan will restart automatically when the defrost thermostat rises above 45°F.

Standard Sequence of Operation

1. The Vertical Stacked main supply fan must be operating in order for the ERV apparatus to operate.
2. ERV fans will be enabled to operate:
 - a. On a call for heating from the thermostat

- b. On a call for cooling from the thermostat
 - c. When thermostat fan selector switch is placed in the “ON” mode
 - d. When a field mounted dry contact remote control switch by others is closed (wired by others, for 120 volts by others).
3. The unit cabinet has a built in bypass relief damper to allow the toilet exhaust fan to exhaust if the unit and/or ERV fans are “OFF”.
 4. All fans will run under normal operation (refer to ERV fan section on page above).
 5. The defrost sensor will detect a frost build up on the heat exchanger based on temperature and will terminate the operation of the fresh air fan until the temperature restores to normal limits (above 45 °F).

ERV Field Reversing

In order to provide installation flexibility, the ERV module orientation can be rotated so the cabinet connections can be reversed. The default configuration has “From Bathroom” duct attaching to the front collar.

On the reversed configuration, the “From Bathroom” duct will attach to the rear collar.

The “From Outside” duct normally attaches to the rear collar but in the reverse configuration, the connection will be on the front.

The “To Outside” duct is always in the middle collar regardless of the configuration. See **Figure 12 and 13** for ERV field reversing instructions.

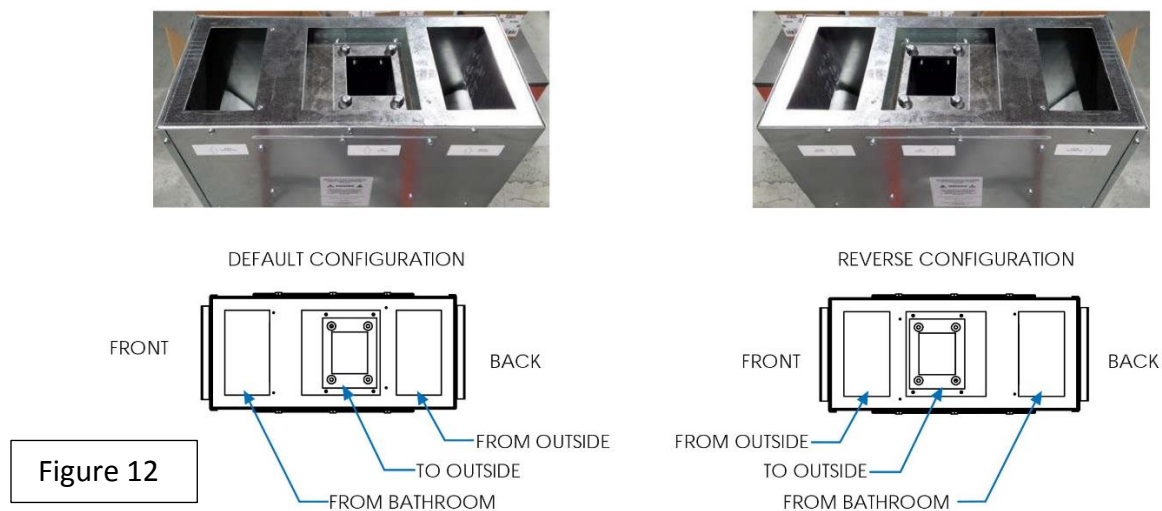
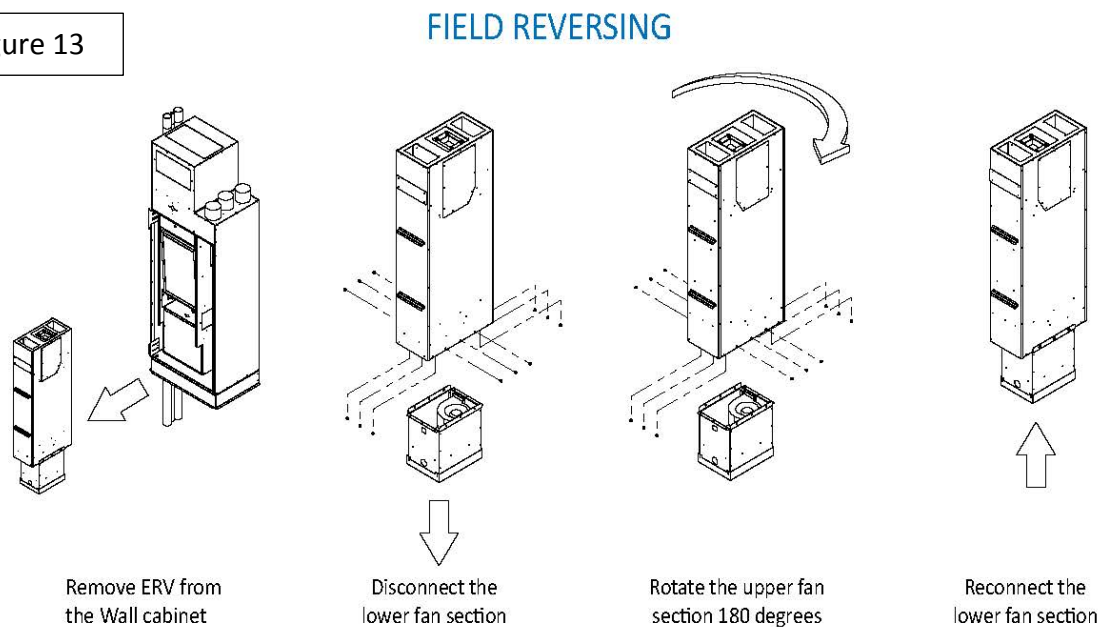

Figure 13



OPERATION -DETAILED

The unit circuit board incorporates six relay outputs with the following uses:

- K1 – Auxiliary relay for cooling valve on a two-valve unit or heat valve on a dehumidification unit.
- K2 – Heating Relay
- K3 – Alarm Relay
- K4 – Compressor Relay
- K5 – Low Fan or Fan Relay for belt drive units
- K6 – High Fan or Compressor #2 on belt drive units

Each of these relays have in parallel, a green LED indicator that illuminates when the relay is energized.

The board incorporates digital inputs that are opto-coupled to a 24V AC source. These inputs have amber LED indicators that will illuminate when an input is present. These inputs include:

- High Pressure Switch
- Low Pressure Switch
- Heat Call (W on thermostat terminal)
- Cool Call (Y on thermostat terminal)
- Fan Call (G on thermostat terminal)
- Auxiliary (A on thermostat terminal)
- Compressor shutdown (24V AC signal thru O/O). Providing a continuous 24V potential to O/O will terminate and prevent compressor operation. This can be used for duty cycling, or for minimizing power consumption during a power failure, while maintaining the heating function.

- Unit shutdown (24V AC signal thru A/O). Providing a continuous 24V AC potential to A/O will terminate and prevent unit operation. This can be used for a simple night shutdown. On both arrangements a single 24V AC signal can shutdown many units. $\frac{1}{4}$ va is required per unit.

The board also has four analog inputs provided via thermistors. These inputs are as follows:

- Ta – Discharge Air Temperature
- Tr – Refrigerant Temperature
- Tw – Outgoing Water (system fluid) Temperature
- Co – Condensate Level

Ta, Tr, And Tw are 10k Ohm NTP thermistors, while Co is a 100 Ohm NPT thermistor. These Inputs do not have LED indicators.

Fan Operation

1. A call on “G” for fan on the thermostat terminal strip will cause the fan to operate continuously on low fan speed through K5 on multi speed units.
2. A call on “W” for heat on the thermostat terminal strip will also cause the fan to operate on low speed. After 10 minutes of a continuous heating call, the multi speed units will be switched to high speed through Relay K6.
3. A call on “Y” for cooling on the thermostat terminal strip will cause the fan on multi speed units to step up to high speed through Relay K6.
4. Fan operation will terminate whenever heating or cooling calls are dropped.
5. Both relays and their associated LED’s are energized when the fan is in high speed.

Heat Operation

A call on “W” for heat will turn on the fan at low speed. Simultaneously, it will energize the heat relay K2 and it’s LED. The relay K2 will provide 24V AC fused power directly to the heat valve.

Cool Start Up

1. A call on “Y” for cooling initiates a series of checks prior to the startup of the compressor. These checks include:
 - a. Power ON timer – Compressor operation is delayed for approximately 5 minutes after restoration of power. This prevents all units coming on-line at the same time once power is restored. It also prevents compressor jolting as a result of intermittent power.
 - b. Anti-Recycle timer – There is a 5-minute anti-recycle delay timer that allows the refrigeration cycle to achieve pressure equalization so that the compressor is unloaded upon start up.
 - c. High Pressure Switch – The high refrigerant pressure switch must be closed prior to start. LED 11 will be ON.
 - d. Low Pressure Switch – The low pressure switch operates primarily as a loss of charge protector. It must be closed for compressor start up and LED 12 will be ON. The pressure switch has a 5 minute ignore subsequent to start-up. In some situations, particularly

- when the unit is cold, the pressure switch will open during start-up. If the switch does not remake within the 5 minute ignore period, the compressor will be immediately stopped.
- e. Air Temperature Sensor Ta – Sensor Ta will prevent compressor operation if the air flowing through the unit is below 40°F (4.4°C).
 - f. Water Temperature Sensor Tw – Sensor Tw will prevent compressor operation if the outgoing system fluid temperature is above 125°F (52°C).
 - g. Refrigerant Temperature Sensor Tr – Sensor Tr will prevent compressor operation if the coil temperature is below 40°F (4.4°C).
 - h. Any of the above faults will be indicated with the Diagnostic Code described under **Diagnostics Table – Page 32**.

Cool Operation

1. Monitoring of the refrigerant cycle continues during operation of the compressor. The following malfunctions will cause the compressor to shut down:
 - a. If the head pressure exceeds the set point of the high pressure switch, it will open, and the control board will terminate the compressor operation within 10 seconds. At this time the flash code 6 will be initiated on the red diagnostic LED. Compressor operation will be restored in accordance with the “Intelligent Reset” algorithm.
 - b. If the suction pressure drops below the set point of the low pressure switch, the switch will open and if it remains open beyond the 5 minute ignore period after start up, compressor operation will be terminated within 10 seconds. Compressor operation will be restored in accordance with the “Intelligent Reset” algorithm. A flash code of 5 on the red diagnostic LED will be initiated at this time.
 - c. **Intelligent Reset Algorithm** – If a low or high pressure switch opens, the compressor will be shut down. There is a 10 minute delay before the system is automatically reset, after which if there is a cool call in place and all other enablers are within the start parameters, the compressor will again be put into operation. Should either of the pressure switches open again, the shutdown procedure will cycle again, followed by a restart. The intelligent reset will allow two open switch shutdowns and restarts in a 24 hour period, but a third shutdown within 24 hours will put the refrigeration system into a full and hard lockout requiring a power down to reset. If two or less switch open shutdowns occur within a 24 hour period, they will be erased from memory and will not contribute to a future hard lockout. (A hard lockout will prevent compressor operation until the controls are powered down for at least 20 seconds, while a soft lockout is a compressor shutdown that will be restored once the conditions causing the shutdown have been rectified.
 - d. During compressor operation, refrigerant temperature, system fluid temperature and discharge air temperature are continuously monitored. If the **refrigerant temperature** drops below 40°F, compressor operation will be disabled. After 10 minutes an auto reset occurs and the compressor will be enabled as soon as the temperature rises above 65°F. Actual compressor restart will be delayed a minimum of 5 minutes by the anti-recycle timer. A flash code of 2 will be initiated upon a low refrigerant temperature shutdown.
 - e. During compressor operation, if the **condenser leaving temperature** rises above 140°F, compressor operation will be disabled. After 10 minutes an auto reset occurs and the compressor will be enabled as soon as the temperature drops below 120°F. The outgoing system fluid sensor is mounted on the leaving fluid pipe. Actual compressor

- restart will be delayed a minimum of 5 minutes by the anti-recycle timer. A flash code of 3 will be initiated upon a high outgoing system fluid temperature shutdown.
- f. If the **discharge air temperature** drops below 40°F compressor operation will be disabled. After 10 minutes an auto reset occurs and the compressor will be enabled as soon as the temperature rises above 55°F. The discharge air temperature sensor is mounted on the fan housing. Actual compressor restart will be delayed a minimum of 5 minutes by the anti-recycle timer. A flash code of 4 will be initiated upon a low discharge air temperature shutdown.
 - g. The condensate level sensor is a 100 ohm thermistor that is heated for 15 seconds every 4 minutes. Its temperature is measured at the beginning of the heat cycle, and again at the end of the heating cycle. If the condensate level rises above the sensor it will not warm up during the warm up cycle, and the temperature change will be insignificant. It is this lack of temperature change that the controller sees as an impending condensate overflow. When high condensate level is detected, compressor operation is immediately terminated, and at the same time the fan is stopped for 30 seconds, and then restarted. At this time a flash code of 7 will be initiated. The 4 minute cycle will continue until the cooling call is no longer in place. If the condensate level drops below the sensor, compressor operation will be returned to normal. However, if the condensate level stays above the sensor for more than 15 minutes, the fault alarm will be triggered. This fault signal will automatically reset once the condensate level goes below the sensor.

Note: The last flash code will be maintained in memory for 1 week or until the unit controls are powered down. The flash code will continue until the problem has cleared and the compressor has been put into operation. If a cooling call is in place, it must be disengaged before the cause of the last alarm shutdown can be identified.

Operation Algorithm Style

There are several control algorithms to prevent cycling and problematic operation. These are:

1. Double Call – If thermostat connections or set up is incorrect resulting in a simultaneous call for both heating and cooling, the unit will not operate. This condition can be observed on the thermostat connection LEDs. (Note: A heat pump thermostat will present this scenario)
2. Reverse Cycle Call – Poorly located automatic changeover thermostats (ie. thermostats mounted on a wall opposite a discharge grill, or a thermostat in a doorway to outside) can trigger heating and cooling mode changes many times an hour. The CGC controller has a 10-minute anti-mode change timer for both heating and cooling mode changes. The controller will not accept a change in mode until 10 minutes have elapsed since termination of the opposite call.

Thermostat Connections Style

The BULLDOG control board has been designed to operate with most standard 24V AC thermostats. These are powered from the CGC board with 24V AC and simply switch power ON to each of the Heat (W), Cool (Y), Fan (G) or Aux (A). While most present day thermostats operate in this manner there are others that may or may not work properly. The following should be checked out for satisfactory performance prior to installation:

1. Heat Pump Thermostat – Some heat pump units do not have heat relays (therefore are not compatible with standard thermostats) and require “Heat Pump Thermostats”. These thermostats call for both heating and cooling on one of the signal wires. These thermostats are completely incompatible with BULLDOG’s controller.

2. Battery powered thermostats – These thermostats were developed as replacements for old mercury bulb thermostats that had 4 wire connections while 24V electronic thermostats required 5 wires. These will work with a CGC board, although CGC does not recommend them. They require periodic battery replacement, which is something that should be avoided if possible.
3. Power stealing thermostats – This type of thermostat is electronic and was also developed as a replacement for old mercury bulb thermostats. These too are problematic in that they bleed a small amount of current down the signal wires and this may be interpreted as a signal for heat or cool.
4. Triac switched controllers – This is a commonly used switching device and all controllers tested to date have functioned flawlessly. CGC recommends that prior to installation of a third party supplied controller, it be checked for compatibility. CGC can confirm this.

Relay switched controllers – This type of controller works well with CGC devices.

Shutdown Output

The BULLDOG board has an optional input terminal strip that allows for two types of remote shutdown. These are a) compressor shutdown and b) unit shutdown.

The advantage of these inputs is that many units can be connected in parallel and when powered by an independent 24V AC signal one or both of these actions can be implemented. Common uses are:

- a. Duty cycling for demand control
- b. Global night setback
- c. Heating only mode during emergency power periods

The BULLDOG controller is also set up so these shutdown functions can be initiated individually with on board 24V power. This capability allows unit or compressor shutdown based on a door switch, a light switch, or occupancy switch. A separate 24V power supply is required if two or more units are being shut down.

Fault Alarm Output

The BULLDOG board is provided with a fault alarm indication and output. The fault alarm relay provides normally open and normally closed contacts for use in transmitting fault conditions. NOTE: The fault alarm is energized for NORMAL, and de-energized for fault. As such, if the unit is not powered, if the board fuse is blown, or if the electronics are damaged, a fault condition will be indicated.

The fault relay is paralleled with the Fault LED which will be ON when no fault condition exists.

Other fault conditions are:

- d. Hard lockout due to high or low pressure switch being open for 10 minutes or longer.
- e. Hard lockout due to three high or low pressure shutdowns in a 24 hour period.
- f. High level condensate for a period in excess of 15 minutes.

COMISSION & STARTUP

System Flushing:

Proper system cleaning and flushing is an important aspect of the commissioning and startup procedure for the units. Ensure the system has been flushed properly. This prevents fouling of the unit's heat exchangers. It is common for debris to settle out in areas of the system where there is low flow or low fluid velocity. This causes nuisance alarms as a result of a fouling heat pump. It is necessary to flush these units out as they appear to contain debris build up. This is the responsibility of the contractor and not a heat pump defect.

NOTE: Hydronic coils are not 100% drainable.

System Fluid:

Ensure that system water temperature is within an acceptable range to facilitate start-up (80-120°F) for cooling and (100 – 140°F) for heating.

System Water pH:

System water should have a neutral pH balance of approximately 7.5 which will extend the life of the hoses, heat exchangers, and other water side accessories.

Water Flow Rate:

Open all isolation valves to the unit. Ensure that the entering and leaving fluid temperatures of the unit in operation are acceptable. There is typically an 8 to 12 degree drop or rise in temperature, depending on whether the unit is in cooling or heating. Under extreme conditions, slight variances in the temperature may be noted.

Freeze Protection from Water System:

Ensure that freeze protection is provided for the outdoor portion of the loop water system. Inadequate freeze protection can lead to coil damage.

NOTE: A potential issue may arise during construction where the system fluid loop is drained after being cleaned, flushed and tested. BULLDOG vertical stacked units will not completely drain and may hold fluid in the condenser or heating coil. Extensive damage may result to internal components if the system fluid freezes unless adequate glycol is added.

Remove Air from System Fluid Loop

Air in the system impairs unit operation and can cause erosion in the system piping.

Air Balancing:

Air balancing of the system should be performed while the unit's fan is operating at high-speed. In order to ensure the fan is operating at high-speed, the unit must be placed into cool mode.

Clean Unit Filters:

Confirm that the unit filters that are being used are clean. This contributes to the proper operation of the unit by ensuring that there is adequate air flow across the coil.

SAFETY NOTE: In the following part of the procedure it will be necessary to access the areas around the electrical wiring and the circuit board. Do not adjust or remove any board connections or wiring connections to other components without first powering down the unit. Disconnects are usually within reach of the unit. **Exercise caution at all times.**

Fan Rotation:

Inspect the fan section to ensure that it is free and clear of any debris and that the fan rotates freely.

NOTE: This equipment is designed for indoor installation ONLY.

Start-up

To register the unit warranty proper start-up is required by a factory approved technician. The following items must be recorded and returned to the factory to register the warranty. The factory reserves the right to refuse warranty if these details are not provided.

Start Up Record

Page _____

Project: _____ Date: _____ Tech: _____

Location _____ Model No. _____ Serial No. _____ Voltage _____ Remarks <div style="border: 1px solid black; height: 60px; width: 100%;"></div>	<table border="1" style="width: 100%; border-collapse: collapse;"> <tr><td style="width: 50px;">H</td><td>EWT</td><td>_____</td></tr> <tr><td>E</td><td>EAT</td><td>_____</td></tr> <tr><td>A</td><td>LAT</td><td>_____</td></tr> <tr><td>T</td><td>Valve</td><td><input type="checkbox"/></td></tr> </table>	H	EWT	_____	E	EAT	_____	A	LAT	_____	T	Valve	<input type="checkbox"/>	<table border="1" style="width: 100%; border-collapse: collapse;"> <tr><td style="width: 50px;">C</td><td>EWT</td><td>_____</td><td>Fan Amps</td><td>_____</td></tr> <tr><td>O</td><td>LWT</td><td>_____</td><td>Compr Amps</td><td>_____</td></tr> <tr><td>O</td><td>EAT</td><td>_____</td><td>Cond.Trap</td><td>_____</td></tr> <tr><td>L</td><td>LAT</td><td>_____</td><td>S/R Correct</td><td><input type="checkbox"/></td></tr> <tr><td colspan="3"></td><td>Sight Glass</td><td><input type="checkbox"/></td></tr> <tr><td colspan="3"></td><td>Belt Tension</td><td><input type="checkbox"/></td></tr> <tr><td colspan="3"></td><td>Fan Rotation</td><td><input type="checkbox"/></td></tr> <tr><td colspan="3"></td><td>Comp Rotation</td><td><input type="checkbox"/></td></tr> </table>	C	EWT	_____	Fan Amps	_____	O	LWT	_____	Compr Amps	_____	O	EAT	_____	Cond.Trap	_____	L	LAT	_____	S/R Correct	<input type="checkbox"/>				Sight Glass	<input type="checkbox"/>				Belt Tension	<input type="checkbox"/>				Fan Rotation	<input type="checkbox"/>				Comp Rotation	<input type="checkbox"/>
H	EWT	_____																																																				
E	EAT	_____																																																				
A	LAT	_____																																																				
T	Valve	<input type="checkbox"/>																																																				
C	EWT	_____	Fan Amps	_____																																																		
O	LWT	_____	Compr Amps	_____																																																		
O	EAT	_____	Cond.Trap	_____																																																		
L	LAT	_____	S/R Correct	<input type="checkbox"/>																																																		
			Sight Glass	<input type="checkbox"/>																																																		
			Belt Tension	<input type="checkbox"/>																																																		
			Fan Rotation	<input type="checkbox"/>																																																		
			Comp Rotation	<input type="checkbox"/>																																																		

S/R = Supply and Return

Location _____ Model No. _____ Serial No. _____ Voltage _____ Remarks <div style="border: 1px solid black; height: 60px; width: 100%;"></div>	<table border="1" style="width: 100%; border-collapse: collapse;"> <tr><td style="width: 50px;">H</td><td>EWT</td><td>_____</td></tr> <tr><td>E</td><td>EAT</td><td>_____</td></tr> <tr><td>A</td><td>LAT</td><td>_____</td></tr> <tr><td>T</td><td>Valve</td><td><input type="checkbox"/></td></tr> </table>	H	EWT	_____	E	EAT	_____	A	LAT	_____	T	Valve	<input type="checkbox"/>	<table border="1" style="width: 100%; border-collapse: collapse;"> <tr><td style="width: 50px;">C</td><td>EWT</td><td>_____</td><td>Fan Amps</td><td>_____</td></tr> <tr><td>O</td><td>LWT</td><td>_____</td><td>Compr Amps</td><td>_____</td></tr> <tr><td>O</td><td>EAT</td><td>_____</td><td>Cond.Trap</td><td>_____</td></tr> <tr><td>L</td><td>LAT</td><td>_____</td><td>S/R Correct</td><td><input type="checkbox"/></td></tr> <tr><td colspan="3"></td><td>Sight Glass</td><td><input type="checkbox"/></td></tr> <tr><td colspan="3"></td><td>Belt Tension</td><td><input type="checkbox"/></td></tr> <tr><td colspan="3"></td><td>Fan Rotation</td><td><input type="checkbox"/></td></tr> <tr><td colspan="3"></td><td>Comp Rotation</td><td><input type="checkbox"/></td></tr> </table>	C	EWT	_____	Fan Amps	_____	O	LWT	_____	Compr Amps	_____	O	EAT	_____	Cond.Trap	_____	L	LAT	_____	S/R Correct	<input type="checkbox"/>				Sight Glass	<input type="checkbox"/>				Belt Tension	<input type="checkbox"/>				Fan Rotation	<input type="checkbox"/>				Comp Rotation	<input type="checkbox"/>
H	EWT	_____																																																				
E	EAT	_____																																																				
A	LAT	_____																																																				
T	Valve	<input type="checkbox"/>																																																				
C	EWT	_____	Fan Amps	_____																																																		
O	LWT	_____	Compr Amps	_____																																																		
O	EAT	_____	Cond.Trap	_____																																																		
L	LAT	_____	S/R Correct	<input type="checkbox"/>																																																		
			Sight Glass	<input type="checkbox"/>																																																		
			Belt Tension	<input type="checkbox"/>																																																		
			Fan Rotation	<input type="checkbox"/>																																																		
			Comp Rotation	<input type="checkbox"/>																																																		

S/R = Supply and Return

Location _____ Model No. _____ Serial No. _____ Voltage _____ Remarks <div style="border: 1px solid black; height: 60px; width: 100%;"></div>	<table border="1" style="width: 100%; border-collapse: collapse;"> <tr><td style="width: 50px;">H</td><td>EWT</td><td>_____</td></tr> <tr><td>E</td><td>EAT</td><td>_____</td></tr> <tr><td>A</td><td>LAT</td><td>_____</td></tr> <tr><td>T</td><td>Valve</td><td><input type="checkbox"/></td></tr> </table>	H	EWT	_____	E	EAT	_____	A	LAT	_____	T	Valve	<input type="checkbox"/>	<table border="1" style="width: 100%; border-collapse: collapse;"> <tr><td style="width: 50px;">C</td><td>EWT</td><td>_____</td><td>Fan Amps</td><td>_____</td></tr> <tr><td>O</td><td>LWT</td><td>_____</td><td>Compr Amps</td><td>_____</td></tr> <tr><td>O</td><td>EAT</td><td>_____</td><td>Cond.Trap</td><td>_____</td></tr> <tr><td>L</td><td>LAT</td><td>_____</td><td>S/R Correct</td><td><input type="checkbox"/></td></tr> <tr><td colspan="3"></td><td>Sight Glass</td><td><input type="checkbox"/></td></tr> <tr><td colspan="3"></td><td>Belt Tension</td><td><input type="checkbox"/></td></tr> <tr><td colspan="3"></td><td>Fan Rotation</td><td><input type="checkbox"/></td></tr> <tr><td colspan="3"></td><td>Comp Rotation</td><td><input type="checkbox"/></td></tr> </table>	C	EWT	_____	Fan Amps	_____	O	LWT	_____	Compr Amps	_____	O	EAT	_____	Cond.Trap	_____	L	LAT	_____	S/R Correct	<input type="checkbox"/>				Sight Glass	<input type="checkbox"/>				Belt Tension	<input type="checkbox"/>				Fan Rotation	<input type="checkbox"/>				Comp Rotation	<input type="checkbox"/>
H	EWT	_____																																																				
E	EAT	_____																																																				
A	LAT	_____																																																				
T	Valve	<input type="checkbox"/>																																																				
C	EWT	_____	Fan Amps	_____																																																		
O	LWT	_____	Compr Amps	_____																																																		
O	EAT	_____	Cond.Trap	_____																																																		
L	LAT	_____	S/R Correct	<input type="checkbox"/>																																																		
			Sight Glass	<input type="checkbox"/>																																																		
			Belt Tension	<input type="checkbox"/>																																																		
			Fan Rotation	<input type="checkbox"/>																																																		
			Comp Rotation	<input type="checkbox"/>																																																		

S/R = Supply and Return

Operational Expectations

The BULLDOG Heat Pump is designed to provide reliable heating and cooling right out of the box. However, transportation and handling damage, service valve leakage, or system problems may cause less than optimum operation. In the event that the qualified commissioning agents suspect there is an operational problem with the heat pump, they need to inform the factory immediately for direction. In certain instances, the factory may request a manifold refrigeration gauge be attached to the heat pump along with thermo-couples to determine the operating parameters of high and low pressure, and super heat and sub cooling. Based on this information the factory may request the charge be adjusted or the refrigeration components be adjusted to optimize cooling operation.



MAINTENANCE

WARNING: To prevent injury or death due to electrical shock or contact with moving parts, disconnect the power to unit before servicing.

Inspect Filters:

Establish a regular maintenance schedule. Clean filters frequently and replace as required. A vacuum can be used to clean filters, as well as the surface of coil components.

To remove the filter from the unit, remove the front service entrance and slide out the filter component.

Check Fan Motors Annually:

Make sure to inspect fan motors for unusual signs of wear. All CGC BULLDOG Heat Pump fan motors are permanently lubricated when shipped from the factory. Do not oil the fan motors.

Amperage Check on Compressor and Fan Motor:

Current draw on this equipment should not exceed normal full load or rated load amps by more than 10 percent of the values noted on the unit nameplate.

Safety Control Reset:

All CGC BULLDOG Heat Pump Systems include high and low pressure switches to prevent the machine from operating under abnormal conditions of temperature or water flow. If multiple pressure alarms occur in 24 hours, the compressor operation will be permanently locked out until the unit is reset, or power is disconnected for 20 seconds.

NOTE: If the heat pump must be reset more than twice, check the unit for a dirty air filter, abnormal entering water temperature, inadequate water flow (delta T method), or internal malfunctions that may be causing high or low pressure conditions. If the unit continues to alarm, contact a trained service technician and ensure the problems are resolved before re-setting the unit again.

ΔT Method: The **normal water temperature differential** for a BULLDOG Heat Pump is 8-15°F (4.4-8.3°C) in heating and 10-15°F (5.5-8.3°C) in cooling.

Drain Pan and Condensate Hose:

Make sure to inspect and clean if necessary, the condensate hose and drain pan on a regular basis.

Refer to BULLDOG Diagnosis table for more details, **Page 32**.



HKV ERV Detail Drawings

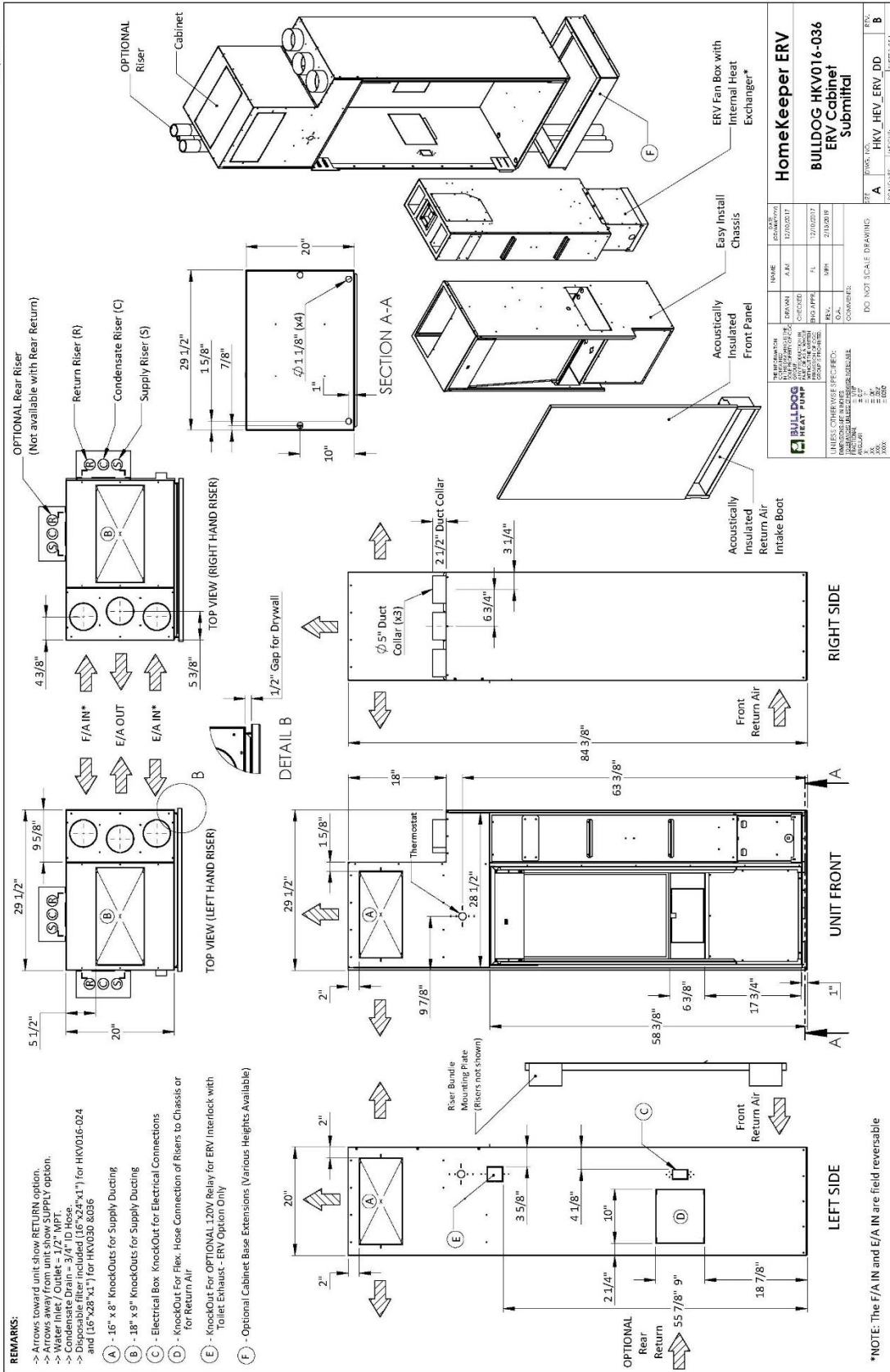

*NOTE: The F/A IN and E/A IN are field reversible
 Last saved on: Friday, February 15, 2019; In the interest of continuous improvement, drawing subject to change without notice.



Generic Wiring Diagram for IKV008-018 Units

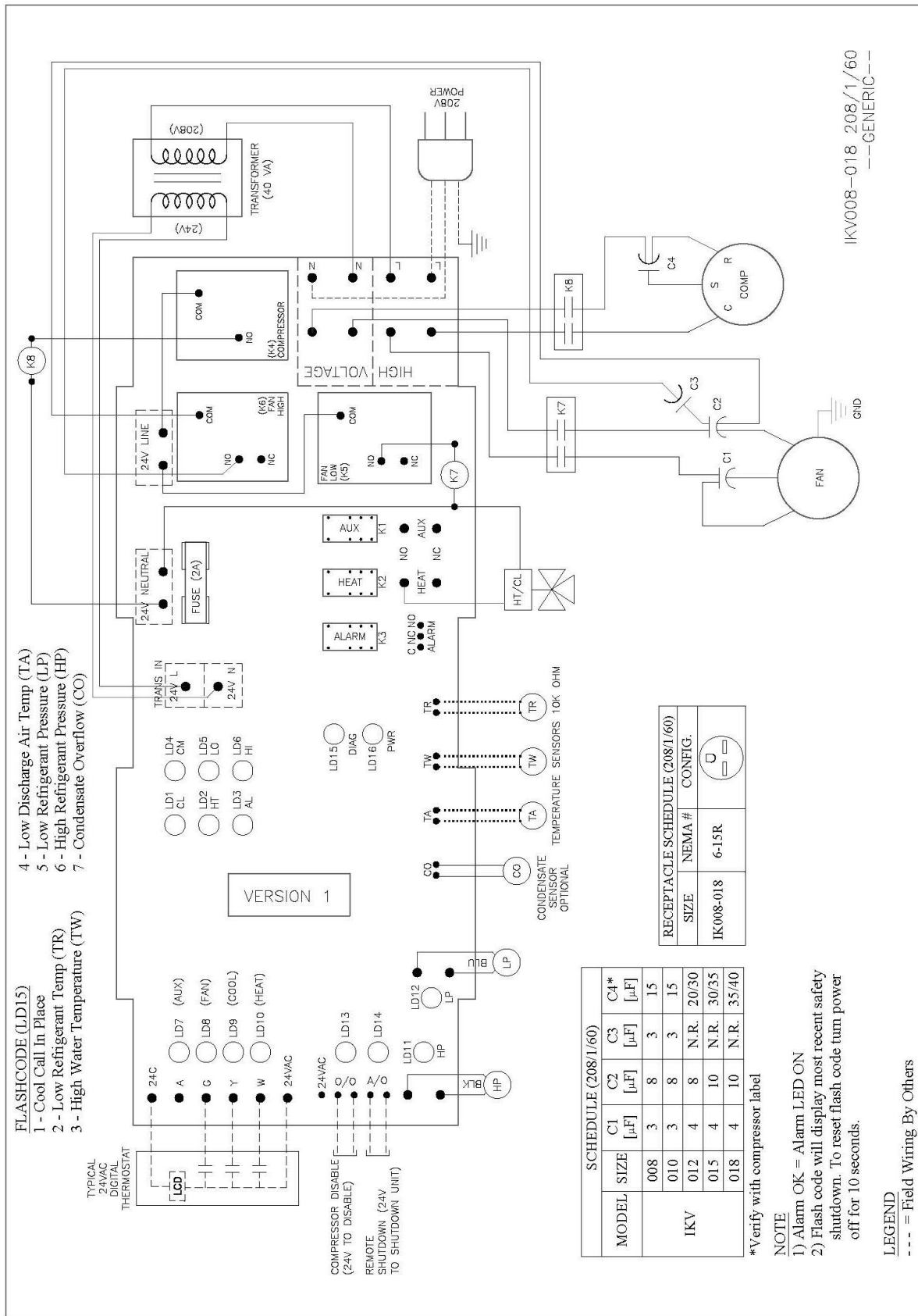

IKV008-018_208/1/60
 ---GENERIC---



Generic Wiring Diagram for HKV016-036 Units

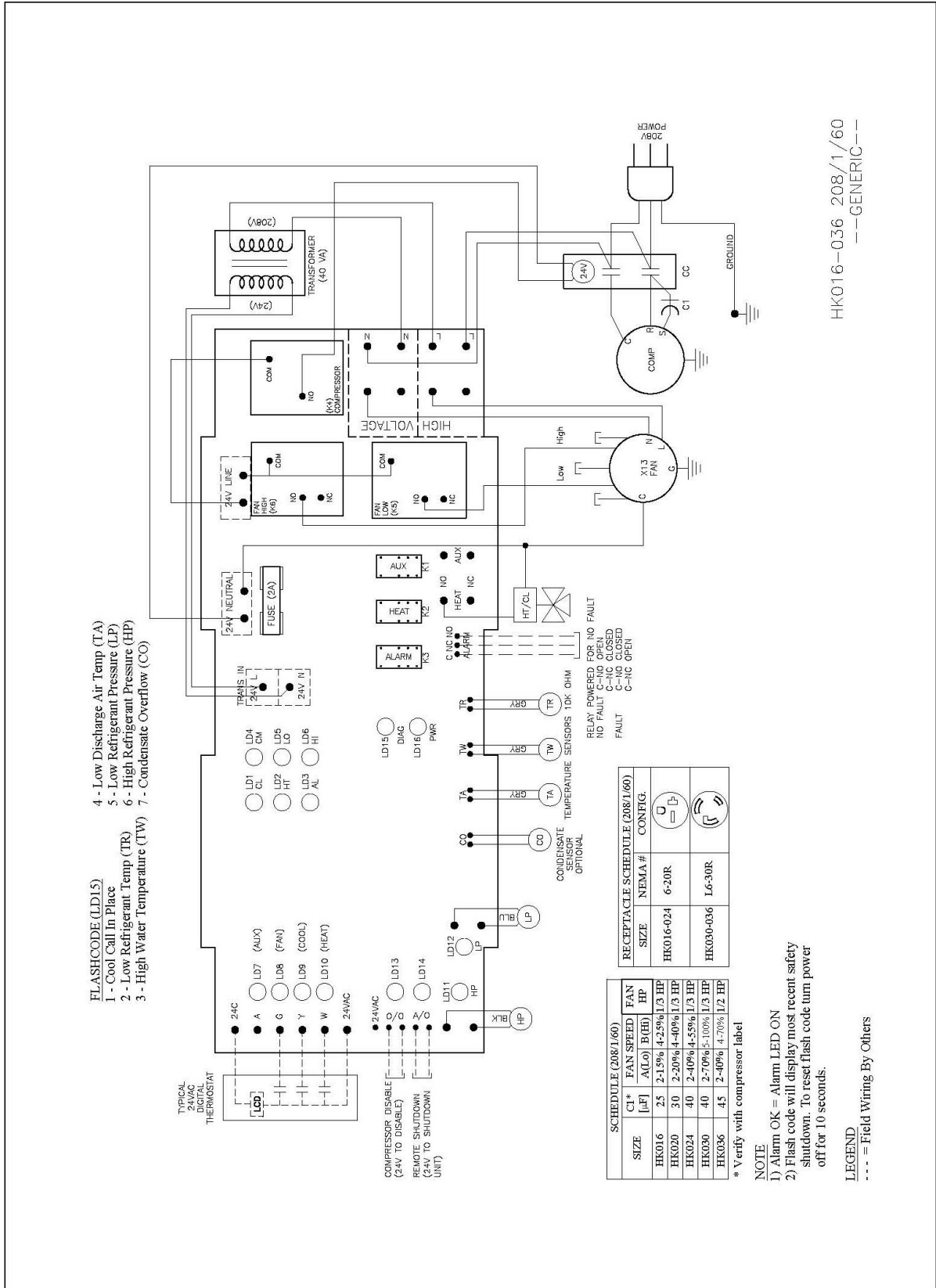

InnKeeper ERV Template

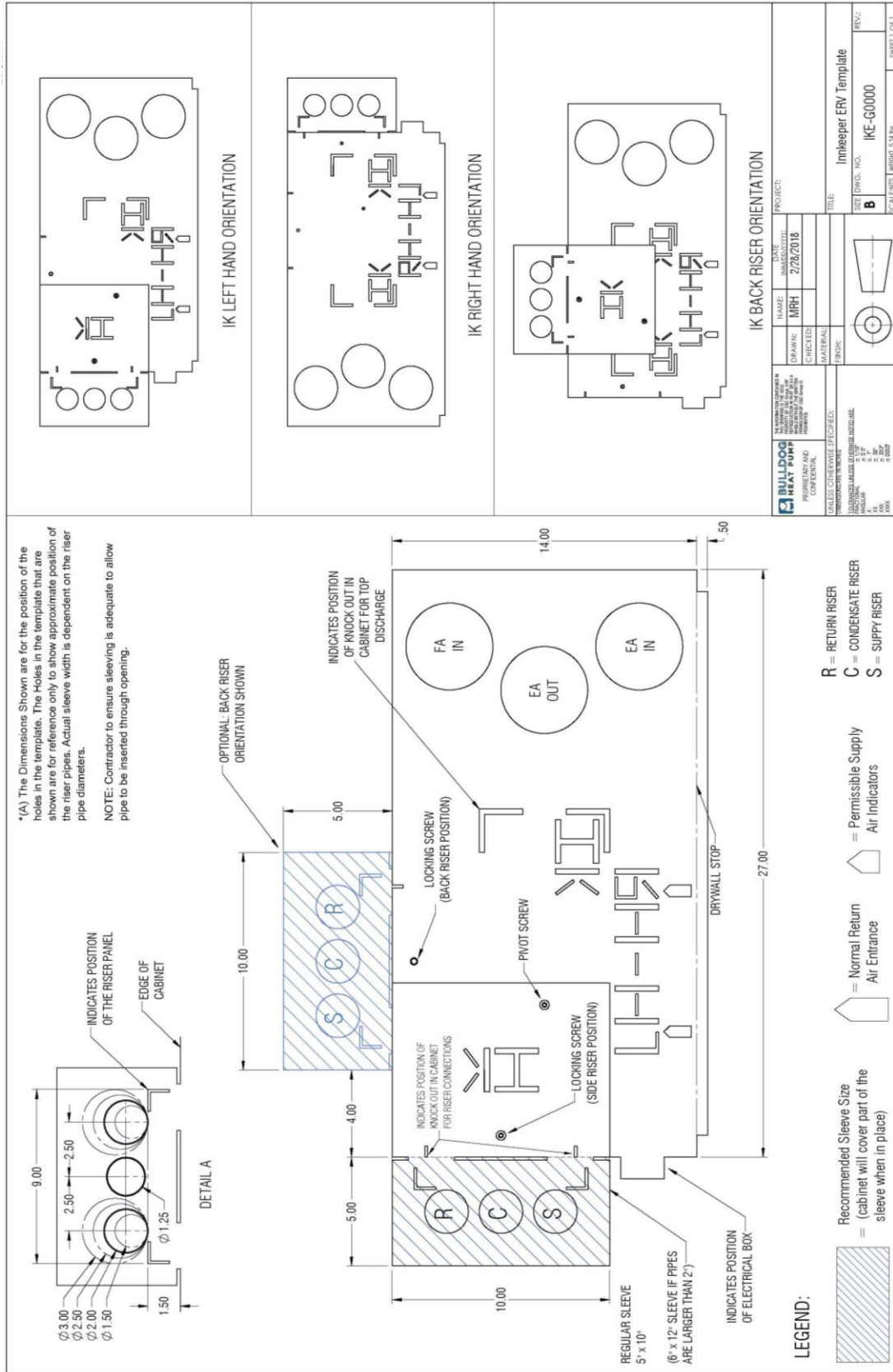

Last saved on: Wednesday, February 28, 2018. In the interest of continuous improvement, drawing subject to change without notice.



HomeKeeper ERV Template

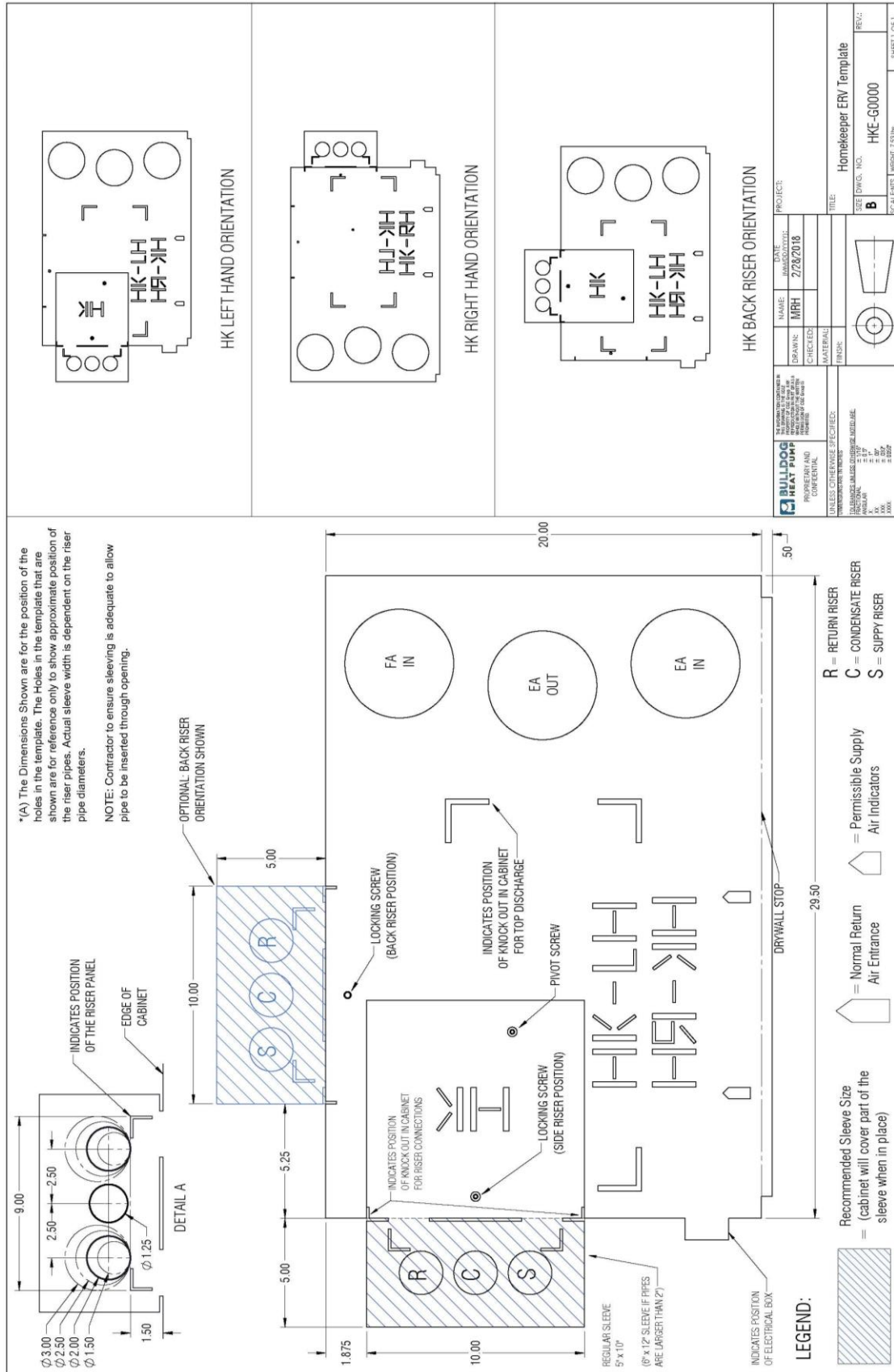

Last saved on: Wednesday, February 28, 2018, in the interest of continuous improvement, drawing subject to change without notice.

Diagnosis Table



Diagnosis Table (HomeK04 Board)

Code (No. of Flashes)	Diagnosis Light	Reason	Possible Cause
0	None	Standby	
1	Cool call in place and compressor running	Ok – compressor running	
2	Low Refrigerant Coil Temperature (TR)	Refrigerant coil is approaching freezing cold temperature (40°F). Disable compressor to prevent buildup of ice on the coil. TR sensor is screwed into evaporator coil frame.	- Restricted Air flow thru unit - Dirty Air Filter - Problem with Fan Motor (check start capacitor if applicable) - Cold Air entering unit (<60°F)
3	“Water Out” temperature (TW)	The leaving water is either too hot or too cold for proper compressor operation. TW sensor is strapped on the “Water Out” pipe.	- Supply water to unit is either 60°F, or above 125°F. Check fluid temperature - Inadequate fluid flow thru unit causing leaving water temperature to be > 140°F when compressor running. Ensure all water valves open. Back flush unit. Verify proper flow (15°F delta T)
4	Low Discharge Air Temperature (TA)	The discharge air temperature falls below 40° F. Disable compressor to prevent blowing uncomfortably cold air, and to prevent more serious low pressure lockout alarm. TA sensors are screwed into the supply fan housing.	- Restricted Air Flow thru unit - Dirty Air Filter - Problem with Fan Motor (check start capacitor if applicable) - Cold Air entering unit (<60°F)
5	Low Refrigerant Pressure	Low suction pressure causes low pressure Switch to open. Low Pressure Switch: Opens at 25 +/- 3 psi (R22) Closes at 50 +/- Open at 60 +/- 3 psi (R410A) Closes at 90 +/- 3 psi	- Restricted Air Flow thru unit - Dirty Air Filter - Problem with Fan Motor (check start capacitor if applicable) - Low Refrigerant Charge (sight glass very bubbly)
6	High Pressure Refrigerant	High pressure causes high pressure switch open. High Pressure Switch: Opens at 375 +/- 10 psi (R22) Closes at 275 +/- 10 psi Opens at 600 +/- 10 psi (R410A) Closes at 450 +/- 10 psi	- Supply water to unit is above 125°F. Check fluid temperature. - Inadequate fluid flow. Ensure all water valves open. Back flush unit. Verify proper flow (15°F delta T) - “Water In” and “Water Out” pipe connections may be reversed - Unit overcharged with refrigerant (flooding condenser)
7	Condensate Overflow	Water level in drain pan too high.	- Block drain line - Pinched Condensate hose - Dirty Air Filter - Insufficient “U” trap - Condensate line double trapped

