

## P74 Series Differential Pressure Controls

### Application

These differential pressure controls are for use as operating controls and/or indicating system functions through display lights or panels. They measure the difference in pressure exerted upon its two sensing elements.

The controls are available for applications sensing air, oil or liquid. Typical applications are proof of flow across a chiller or water cooled condenser, proof of flow in a heating or cooling coil and lube oil pressure sensing on refrigeration compressors. On a proof of flow application the control measures pressure drop across two different points in either a closed water circulating system or a city water to supply system.



**Fig. 1: P74 Differential Pressure Control with Style 13 elements.**

### Specifications

<b>Type Number</b>	<b>P74AA</b>	SPST, Contacts Open on Differential Pressure Increase
	<b>P74AB</b>	SPST, Contacts Open on Differential Pressure Increase, Manual Reset
	<b>P74BA</b>	SPST, Contacts Close on Differential Pressure Increase
	<b>P74CA</b>	DPST, Contacts Open on Differential Pressure Increase
	<b>P74CB</b>	DPST, Contacts Open on Differential Pressure Increase, Manual Reset
	<b>P74DA</b>	DPST, Contacts Close on Differential Pressure Increase
	<b>P74DB</b>	DPST, Contacts Close on Differential Pressure Increase, Manual Reset
	<b>P74EA</b>	SPDT, Standard Switch Differential
	<b>P74FA</b>	SPDT, Narrow Switch Differential
	<b>P74GA</b>	Main Contacts Open on Differential Increase, Separate Auxiliary Contacts Close
<b>P74HA</b>	Main Contacts Close on Differential Increase, Separate Auxiliary Contacts Open	
<b>Ambient Temperature</b>	<b>Minimum</b>	32°F (0°C)
	<b>Maximum</b>	104°F (40°C)
<b>Conduit Opening</b>	3/8" (22 mm) Diameter Hole for 1/2" Conduit	
<b>Contact Unit</b>	<b>P74A, P74B, P74C, P74D, P74G, P74H</b>	Large Copper Backed Silver Contacts and Beryllium Copper Conductor Leaves
	<b>P74E, P74F</b>	SPDT, Snap-Acting Contacts in Dust Protected Enclosure
<b>Differential</b>	See Table	
<b>Finish</b>	Gray Baked	
<b>Material</b>	<b>Case</b>	.062" (1.6 mm) Cold Rolled Steel
	<b>Cover</b>	.028" (0.7 mm) Cold Rolled Steel
<b>Maximum Pressure</b>	See Table	
<b>Mounting Bracket</b>	Universal Mounting Bracket Part No. 271-51 Supplied as Standard	
<b>Range</b>	See Table	
<b>Shipping Weight</b>	<b>Individual Pack</b>	2.4 lb (1.1 kg)
	<b>Overpack of 20</b>	50.5 lb (22.9 kg)
	<b>Bulk Pack of 25</b>	57 lb (25.9 kg)

On a proof of flow application in a water chiller system the control activates a light or signal to indicate a loss of water.

The control may also be applied as a lube oil pressure sensing control on refrigeration compressors. They may be used in combination with P28 and/or P45 oil pressure cutout controls on two compressor, single motor units to reduce the oil system cost. (See Fig. 4.) Special low pressure models are available for variable speed and screw compressor oil pressure applications.

**All Series P74 differential pressure controls are designed for use *only* as operating controls. Where an operating control failure would result in personal injury and/or loss of property, it is the responsibility of the installer to add devices (safety, limit controls) or systems (alarm, supervisory systems) that protect against, or warn of, control failure.**

## Range and Differential Specifications

Differential Pressure Range PSI kPa	Switch Differential PSI kPa		Maximum Differential Pressure Between the Bellows PSI kPa	Maximum Low Pressure Bellows Overrun* PSIG kPa	Bellows Material	
	P74A, P74B, P74C, P74D, P74G, P74H	P74E P74F				
2 to 26 14 to 180	—	3.5 Fixed 24	1.2 Fixed 8	120 830	180 1241	Brass
8 to 60 50 to 400	6 to 20 Adj. 41 to 138	3.8 Fixed 26	1.5 Fixed 10	120 830	180 1241	Brass
2 to 30 14 to 207	—	5.0 Fixed 34	2.0 Fixed 14	200 1379	180 1241	Stainless Steel
8 to 70 50 to 450	8 to 30 Adj. 55 to 207	5.5 Fixed 38	2.5 Fixed 17	200 1379	180 1241	Stainless Steel

\*Bellows overrun pressure is the pressure supplied to the low pressure side of the control.

### Features

- Heavy duty, low profile elements withstand unduly high overrun pressures that may be encountered in shipment or in some machine rooms.
- Lockout models have a “trip-free” manual reset.
- Long life contact structure with high contact force -- no contact bounce.
- Single unit mounting and wiring -- saves installation time and material.

### General Description

Single and double pole models are available with contacts that open on a pressure differential increase or close on a pressure differential increase. Also available are models with single-pole, double-throw enclosed contacts or with main and separate reverse-acting auxiliary contacts. Controls with lockout feature require manual reset to reclose circuit after lockout. The “trip-free” reset will not permit restart until reset button is pushed and released.

The operation point of the control is readily adjusted by rotating the adjusting disk. The control set points are easily read on a calibrated scale.

### Electrical Ratings

#### P74AA, P74AB, P74BA

Motor Ratings	1 Phase			
	120 V	208 V	240 V	277 V
AC Full Load Amp	20.0	18.7	17.0	—
AC Locked Rotor Amp	120.0	112.2	102.0	—
AC Non-Inductive Amp	22.0	22.0	22.0	—
Pilot Duty — 125 VA, 120 to 600 VAC; 57.5 VA, 120 to 300 VDC				

#### P74CA, P74CB, P74DA, P74DB

Motor Ratings	1 Phase			Polyphase	
	120 V	208 V	240 V	277 V	208 V 240 V
Horsepower	2	3	3	—	5 5
AC Full Load Amp	24.0	18.7	17.0	—	16.5 15.0
AC Locked Rotor Amp	144.0	112.2	102.0	—	99.0 90.0
AC Non-Inductive Amp	24.0	24.0	24.0	22.0	—
Pilot Duty — 125 VA, 120 to 600 VAC; 57.5 VA, 120 to 300 VDC					

#### P74EA

Motor Ratings	120 V	208 V	240 V	277 V
AC Full Load Amp	16.0	9.2	8.0	—
AC Locked Rotor Amp	96.0	55.2	48.0	—
AC Non-Inductive Amp	16.0	16.0	16.0	16.0
Pilot Duty — 125 VA, 120 to 600 VAC				

#### P74FA

Motor Ratings	120 V	208 V	240 V	277 V
AC Full Load Amp	6.0	3.4	3.0	—
AC Locked Rotor Amp	36.0	20.4	18.0	—
AC Non-Inductive Amp	10.0	10.0	10.0	10.0
Pilot Duty — 125 VA, 120 to 277 VAC				

#### P74GA, P74HA

Pole Number Motor Rating	LINE-M2 (Main)				LINE-M1 (Auxiliary)			
	120 V	208 V	240 V	277 V	120 V	208 V	240 V	277 V
AC Full Load Amp	16.0	9.2	8.0	—	6.0	3.3	3.0	—
AC Locked Rotor Amp	96.0	55.2	48.0	—	36.0	19.8	18.0	—
AC Non-Inductive Amp	16.0	9.2	8.0	7.2	6.0	6.0	6.0	6.0
Pilot Duty, Both Poles — 125 VA, 120 to 600 VAC; 57.5 VA, 120 to 300 VDC								

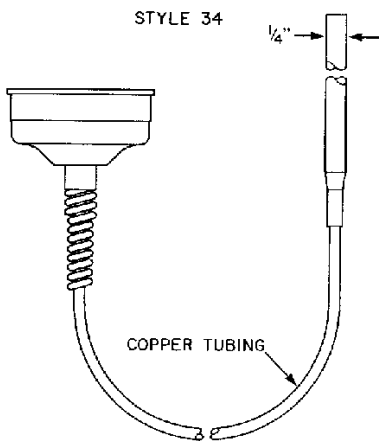
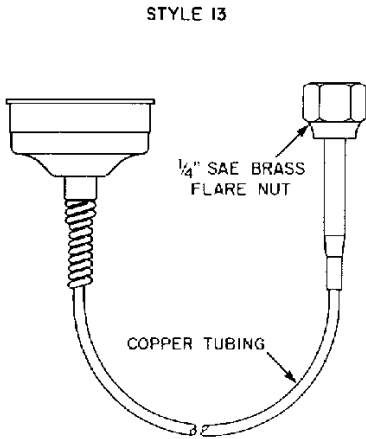
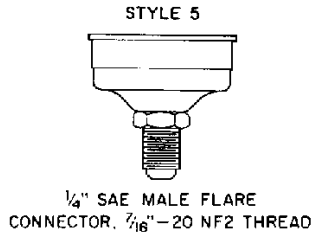

Fig. 2: Pressure element styles available on the P74. Style 13 is standard. Other styles shown above can be supplied on quantity orders.

## Optional Constructions

### Pressure Elements

Regularly supplied for non-corrosive refrigerants (fluorinated hydrocarbons). Available for ammonia service with 1/4 in. - 18 FNPT connector. (See Style Chart, Fig. 2.)

### Pressure Connectors

Standard controls supplied with 36 in. capillary tubing with 1/4 in. flare nut (Style 13). Controls with 1/4 in. SAE male flare connector (no capillary tubing, Style 5), 36 in. capillary tubing with 1/4 in. sweat section (Style 34), or 1/4 in. FNPT connector (Style 15) may be supplied on quantity orders (see Pressure Element Styles).

## Repairs and Replacement

Field repairs must not be made. For a replacement control, contact the nearest Johnson Controls distributor.

## Ordering Information

To order, specify:

- Quantity required.

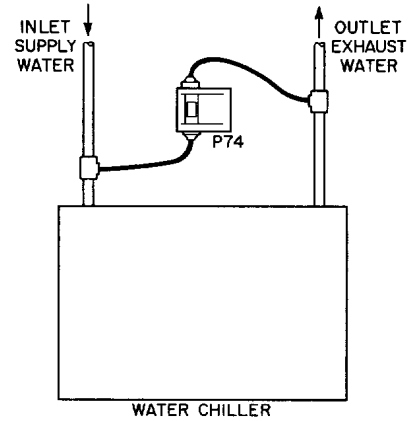

Fig. 3: Typical proof of flow hookup.

- Complete Product Number, if available.
- If complete Product Number is not available, specify Type Number (see Specifications table) and the following.
- Type of refrigerant or fluid.
  - Non-corrosive.
  - Ammonia.
- Style of pressure connector.
- Optional constructions.
- Setting -- contacts close at \_\_\_\_\_ and open at \_\_\_\_\_.

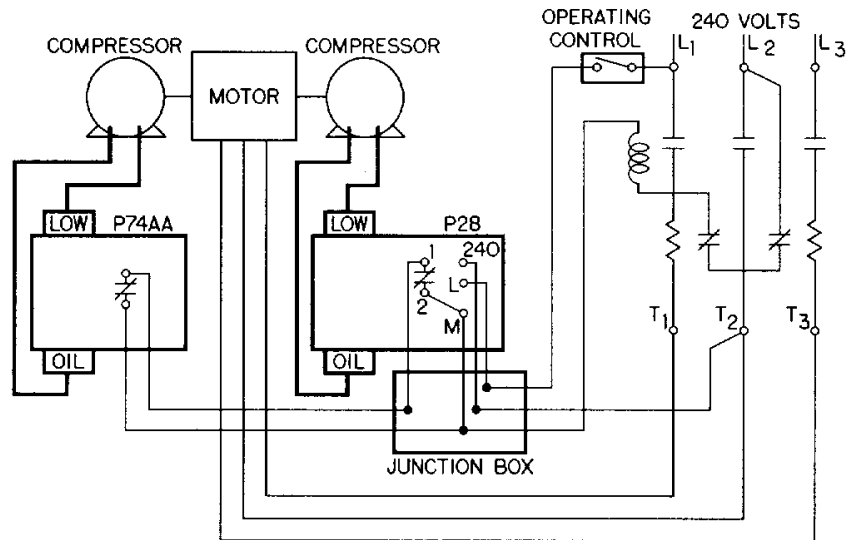
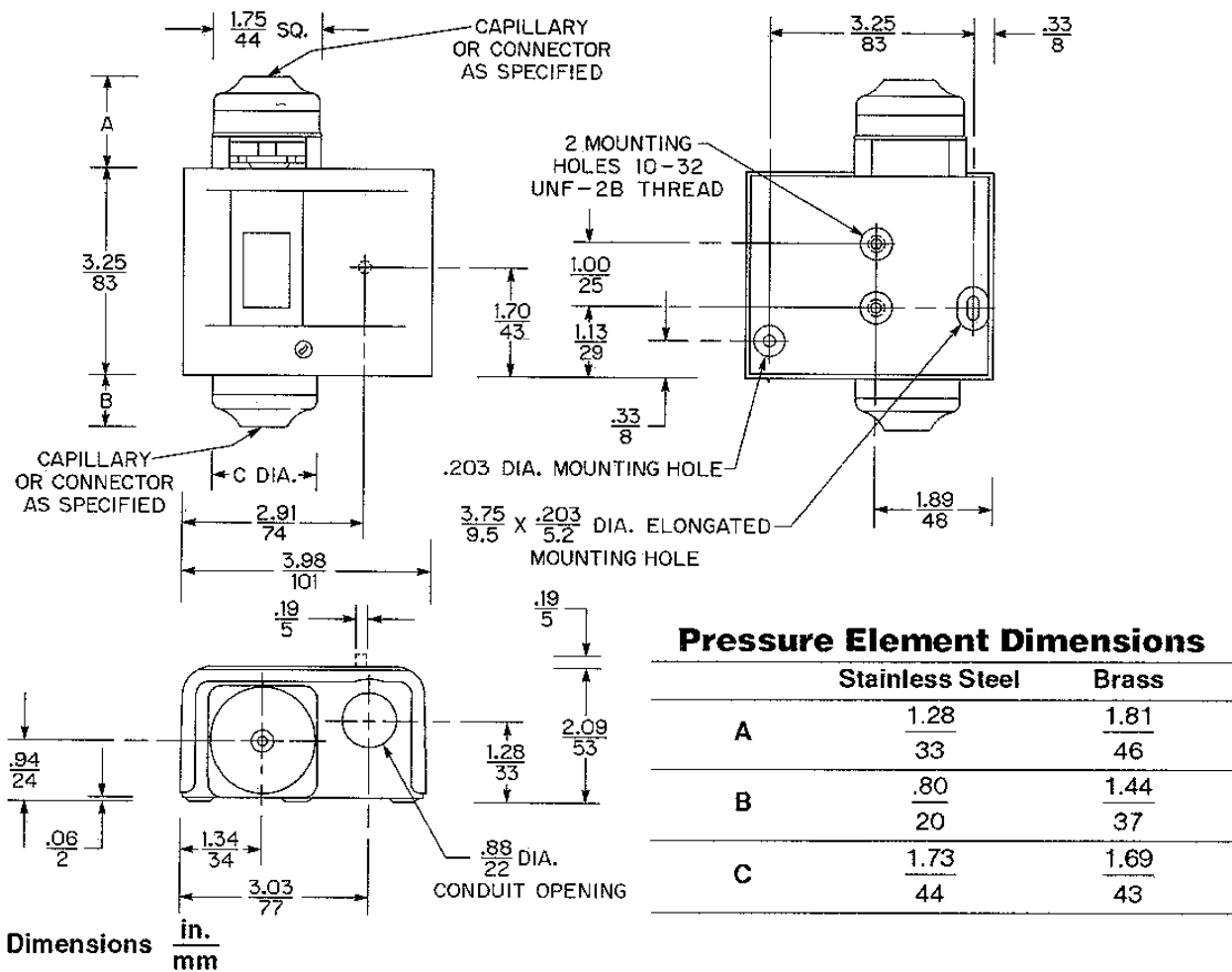

Fig. 4: Typical wiring diagram showing the P74AA and a P28 on a motor operating two compressors.



Performance specifications appearing herein are nominal and are subject to accepted manufacturing tolerances and application variables.

**JOHNSON  
CONTROLS**

Controls Group  
507 E. Michigan Street  
P.O. Box 423  
Milwaukee, WI 53202

Printed in U.S.A.

