

200N Michigan Ave
Chicago, IL



Varipak

Make Up Air Unit
Product Guide



Table of Contents

Model Nomenclature.....	1
Capacities.....	2
Unit Dimensions.....	3
Varipak Construction.....	4
Rooftop Units (VPRO-VPR6).....	6
Indoor Units (VPA0-VPA6).....	8
How do they work?.....	10
Why and Where to Use the Varipak.....	12
Generic Power/Controls Diagram.....	13
General Specifications.....	14
Options.....	17



Model Nomenclature

VP	E	A	5	56	Options
<u>Varipak</u>	<u>Cabinet</u> S - Standard E - Runaround W- Thermal Wheel	<u>Product type</u> A - Indoor R - Rooftop	<u>Model Size</u> 0 - 4000 CFM 1 - 5000 CFM 2 - 7500 CFM 3 - 10,000 CFM 4 - 12,000 CFM 5 - 16,000 CFM 6 - 20,000 CFM 7 - 25,000 CFM 8 - 30,000 CFM	<u>Nominal Capacity</u> 10 - 10 TONS (120 MBH) 12 - 12 TON (144 MBH) 15 - 15 TONS (180 MBH) 18 - 18 TONS (216 MBH) 20 - 20 TONS (240 MBH) 22 - 22 TONS (264 MBH) 25 - 25 TONS (300 MBH) 28 - 28 TONS (336 MBH) 30 - 30 TONS (360 MBH) 35 - 35 TONS (420 MBH) 40 - 40 TONS (480 MBH) 45 - 45 TONS (540 MBH) 50 - 50 TONS (540 MBH) 60 - 56 TONS (672 MBH) 70 - 68 TONS (840 MBH) 80 - 78 TONS (960 MBH) 90 - 90 TONS (1090 MBH) 110 - 110 TONS (1300 MBH) 125 - 125 TONS (1500 MBH)	
				Consult Factory	

General Features

- 100% outdoor air capability (neutral air temperature delivery)
- Installed indoor or outdoor
- Up to 120 tons and 30,000 cfm
- Mechanical cooling and hydronic heating
- Low sound level
- Low flow rate (2 gpm/ton) = lower pumping energy
- Reduces fluid cooler operations by using FreeHeat™
- Horizontal end discharge or top vertical discharge
- Double skin
- Variable Air Volume

Model Capacity - Tonnage Options

This lists the available capacities in tons for each Varipak units by model box size.

Shade boxes indicates available standard model. Consult factory if other specifications are required.

Capacity	Model Size								
	VP0	VP1	VP2	VP3	VP4	VP5	VP6	VP7	VP8
10	Y	Y							
12	Y	Y							
15	Y	Y	Y						
18	Y	Y	Y						
20	Y	Y	Y	Y					
22		Y	Y	Y					
25		Y	Y	Y	Y				
28		Y	Y	Y	Y				
30					Y	Y	Y	Y	Y
35					Y	Y	Y	Y	Y
40					Y	Y	Y	Y	Y
45					Y	Y	Y	Y	Y
50					Y	Y	Y	Y	Y
56					Y	Y	Y	Y	Y
60							Y	Y	Y
70							Y	Y	Y
80							Y	Y	Y
90								Y	Y
110								Y	Y
125								Y	Y

Table 1

Available Static Pressure at Nominal CFM

All static pressures in inches water column.

Model	Static Pressure Maximum		
	TSP	ISP	ESP
VP0	4.25	3.25	1.00
VP1	4.25	3.00	1.25
VP2	4.25	2.75	1.50
VP3	4.25	2.50	1.75
VP4	4.25	2.25	2.00
VP5	4.75	2.75	2.00
VP6	4.75	2.75	2.00
VP7	4.75	2.75	2.00
VP8	5.00	2.75	2.25

Table 2



Unit Dimensions and Weights

All dimensions in inches and weights in pounds and represent an indoor horizontal floor mounted unit.

Unit Dimensions (inches)				
Model	Height	Length	Width	Approx. Weight (lb)
VP0	51	46	90	1,400
VP1	42	98	99	2,700
VP2	54	98	99	4,000
VP3	66	98	99	4,500
VP4	66	122	99	5,100
VP5	78	122	99	5,500
VP6	90	122	99	6,000
VP7	102	122	99	6,200
VP8	114	122	99	7,200

Table 3 Dimensions and weights are **not** to be used for construction. Weights may change with capacities and options.

Unit Selection

Model Size	CFM*
	Nominal
VP0	4000
VP1	5000
VP2	7500
VP3	10000
VP4	12000
VP5	16000
VP6	20000
VP7	25000
VP8	30,000

Table 4
*Without heat recovery



Varipak Construction

The VP1 and larger are designed with a welded steel structural base. Lifting holes are added to the base for rigging purposes.

The cabinet is constructed with heavy gauge galvanized steel. The exterior surfaces are treated with an epoxy based, baked enamel finish. The walls, roof, and floor are double skinned and filled with 2" rigid foam insulation (R10 value). Service doors are double skinned and hung with heavy duty stainless steel hinges. The lockable handles are designed at a comfortable height with latch extensions.



The fans and motors are mounted on a welded steel base with vibration isolators. The fans are commercial grade, heavy duty, double inlet forward curved and the belt drives are specified for 150% service factor. The drain and coil pans are made with stainless steel. The standard filter arrangement includes a 2" disposable prefilter followed by 15" MERV 11 - 14 bag filters. All Varipaks are factory wired for single point electrical connection and piping is designed for a single point supply and return fluid connection.



Epoxy based, baked enamel finish for protection against the elements.



The Varipak is based on an integral frame and panel design with multiple full height hinged doors arranged for easy service access.



Heavy duty hardware is added for durability in all kinds of weather.



Door latching - single handle 2 or more latches.

Rooftop Units

VPR 0

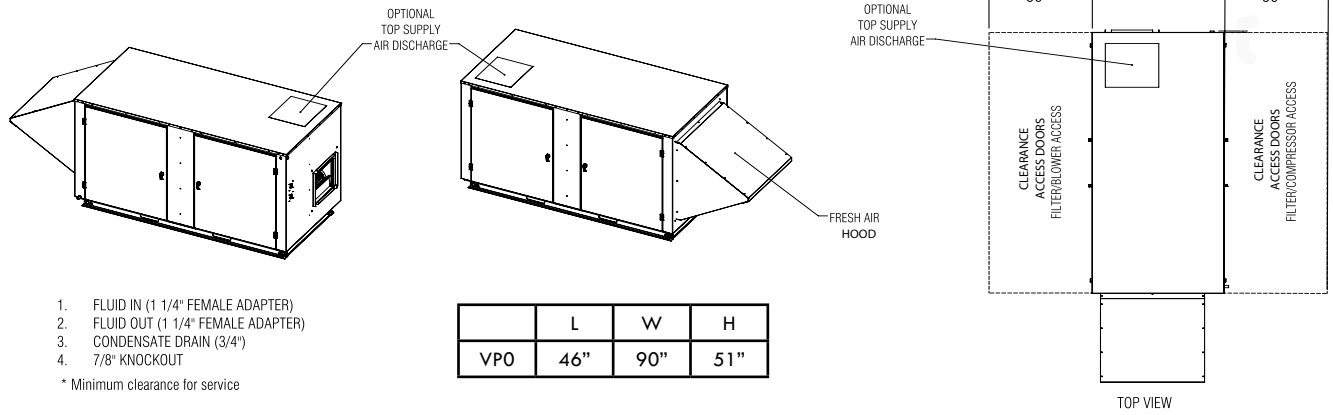

1. FLUID IN (1 1/4" FEMALE ADAPTER)
 2. FLUID OUT (1 1/4" FEMALE ADAPTER)
 3. CONDENSATE DRAIN (3/4")
 4. 7/8" KNOCKOUT
- * Minimum clearance for service

	L	W	H
VPO	46"	90"	51"

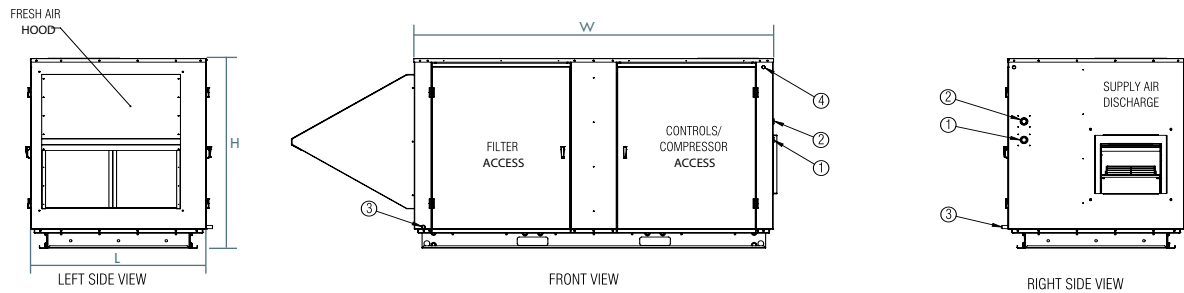

VPR 1,2,3

	L	W	H
VP1	98"	99"	42"
VP2	98"	99"	54"
VP3	98"	99"	66"

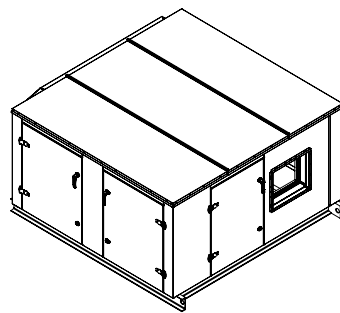

1. FLUID IN*
 2. FLUID OUT*
 3. CONDENSATE DRAIN x 2 (1 1/2")
 4. SUGGESTED AREA FOR ELECTRICAL CONNECTION. TO BE FIELD INSTALLED BY OTHERS
- * Mechanical grooved coupling supplied by manufacturer
 ** Minimum clearance for service

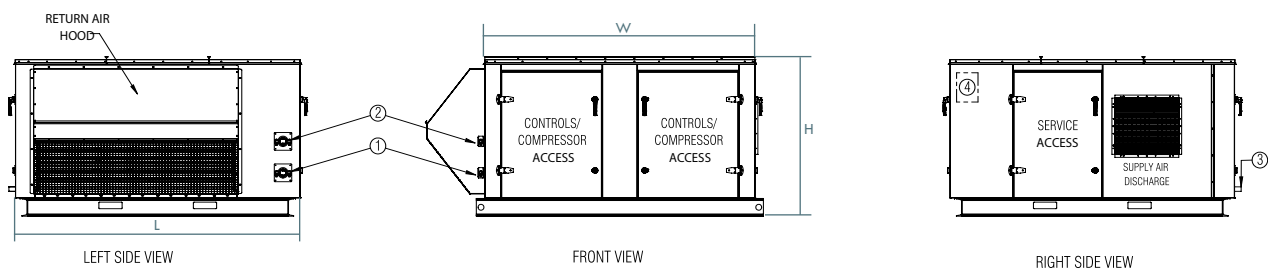
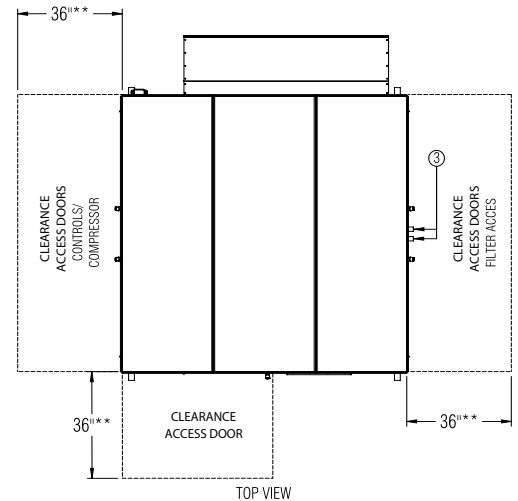



VPR 4,5

	L	W	H
VP4	122"	99"	66"
VP5	122"	99"	78"

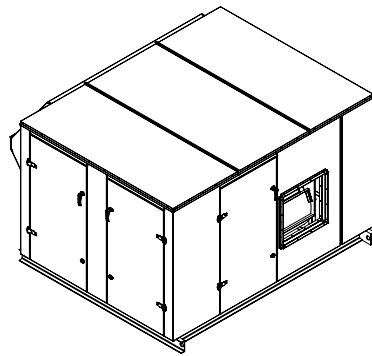

1. FLUID IN*
 2. FLUID OUT*
 3. CONDENSATE DRAIN x 2 (1 1/2")
 4. SUGGESTED AREA FOR ELECTRICAL CONNECTION, TO BE FIELD INSTALLED BY OTHERS
- * Mechanical grooved coupling supplied by manufacturer
 ** Minimum clearance for service

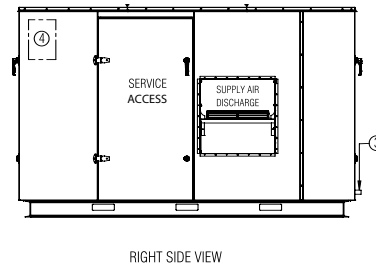
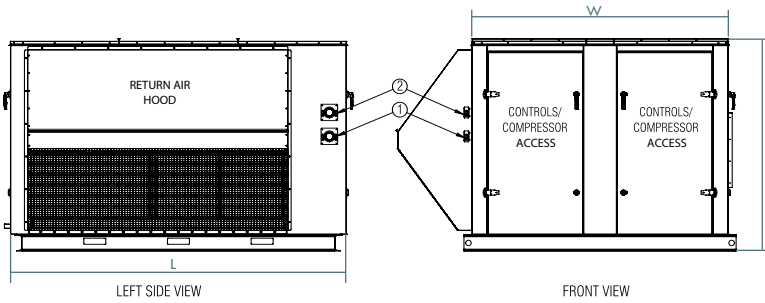
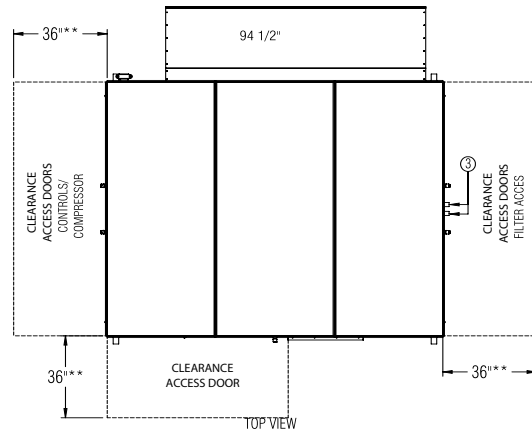

VPR 6,7,8

	L	W	H
VP6	98"	99"	90"
VP7	98"	99"	102"
VP8	98"	99"	114"

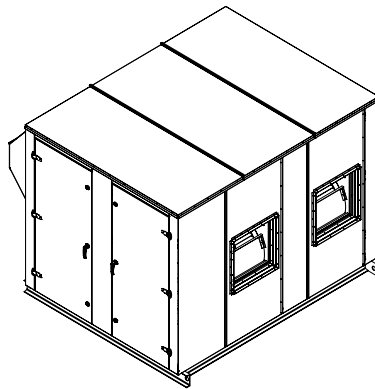

1. FLUID IN*
 2. FLUID OUT*
 3. CONDENSATE DRAIN x 2 (1 1/2")
 4. SUGGESTED AREA FOR ELECTRICAL CONNECTION, TO BE FIELD INSTALLED BY OTHERS
- * Mechanical grooved coupling supplied by manufacturer
 ** Minimum clearance for service

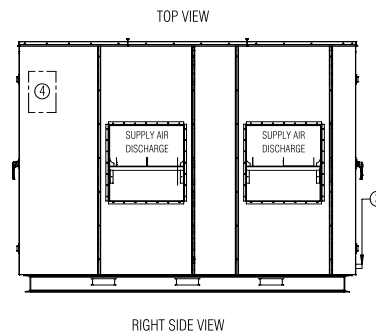
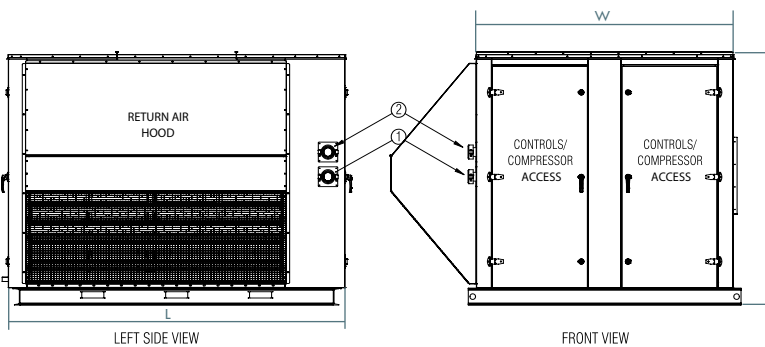
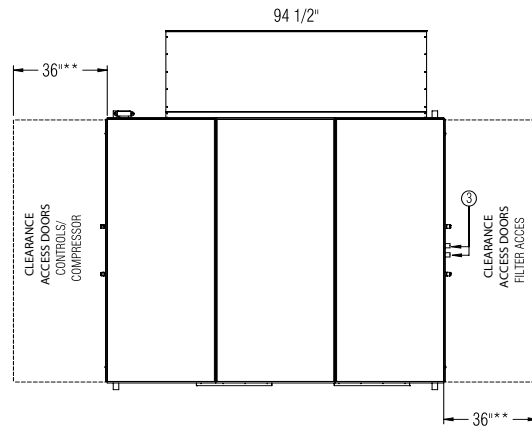

Indoor Units

VPA 0

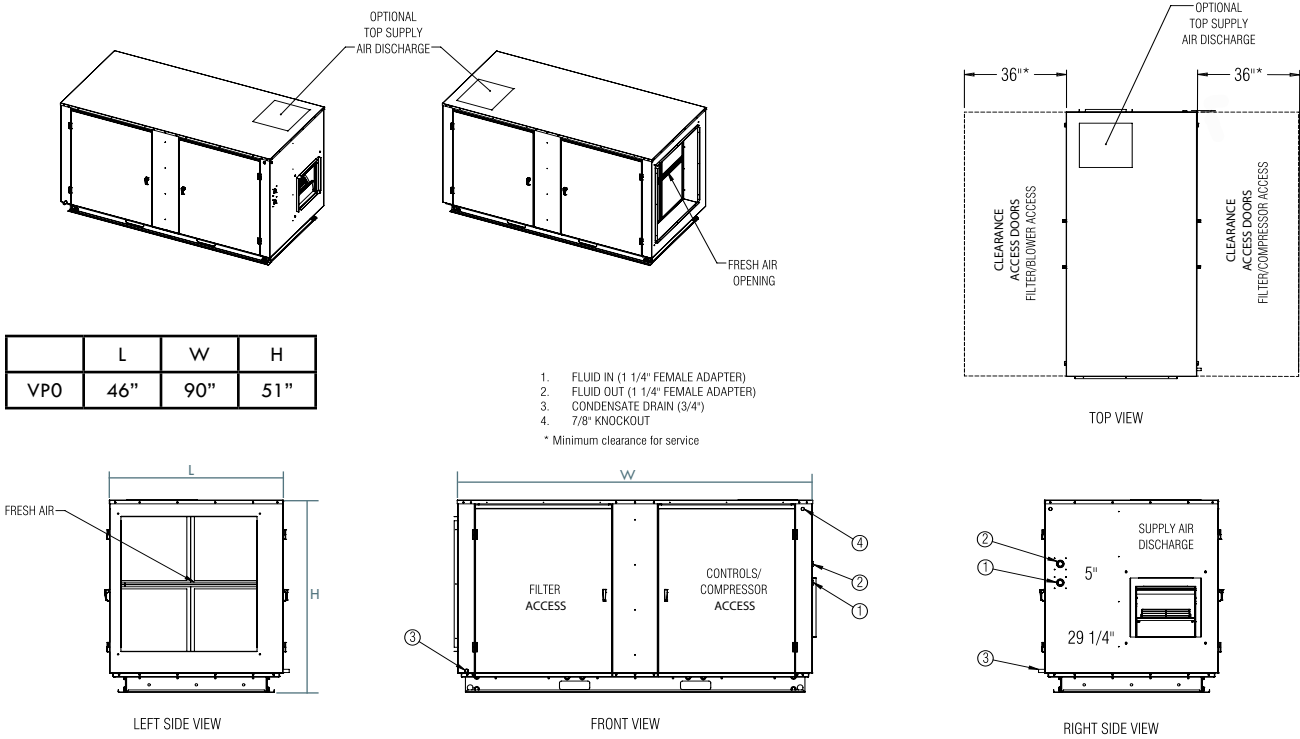

VPA 1,2,3

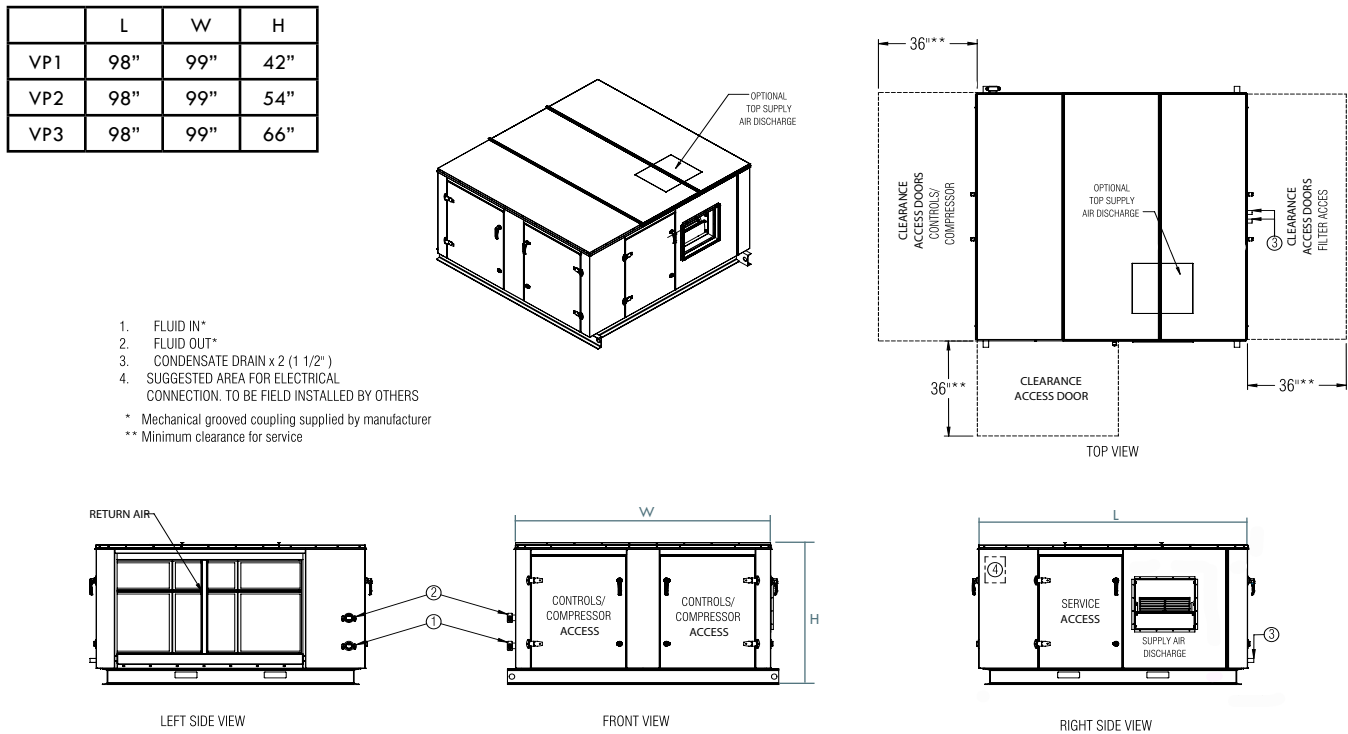



VPA 4,5

	L	W	H
VP4	122"	99"	66"
VP5	122"	99"	78"

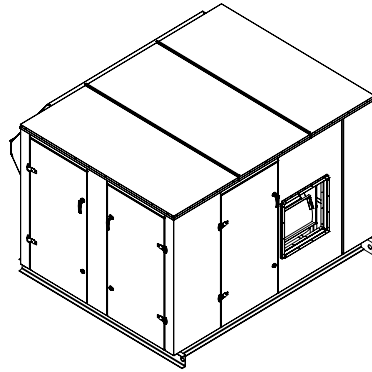

1. FLUID IN*
 2. FLUID OUT*
 3. CONDENSATE DRAIN x 2 (1 1/2")
 4. SUGGESTED AREA FOR ELECTRICAL CONNECTION. TO BE FIELD INSTALLED BY OTHERS
- * Mechanical grooved coupling supplied by manufacturer
 ** Minimum clearance for service

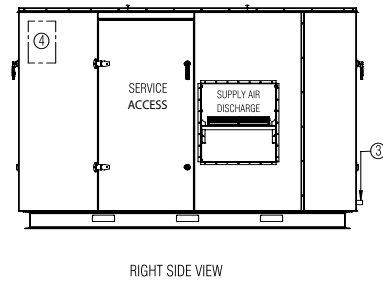
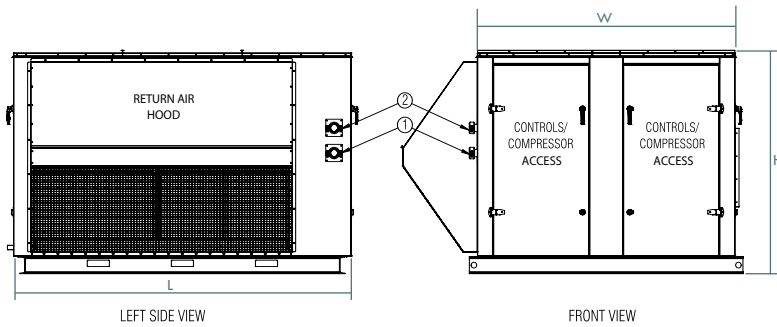
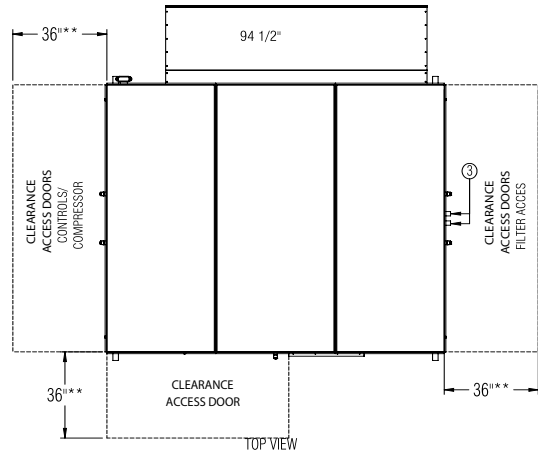

VPA 6,7,8

	L	W	H
VP6	98"	99"	90"
VP7	98"	99"	102"
VP8	98"	99"	114"

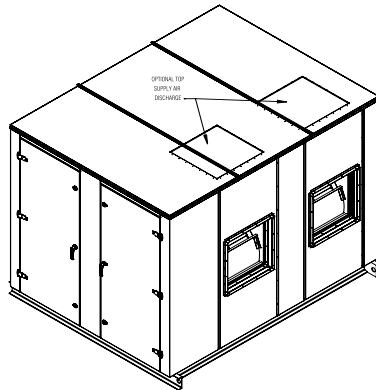

1. FLUID IN*
 2. FLUID OUT*
 3. CONDENSATE DRAIN x 2 (1 1/2")
 4. SUGGESTED AREA FOR ELECTRICAL CONNECTION. TO BE FIELD INSTALLED BY OTHERS
- * Mechanical grooved coupling supplied by manufacturer
 ** Minimum clearance for service

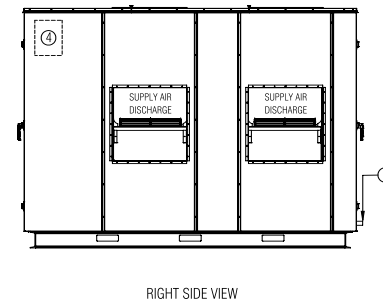
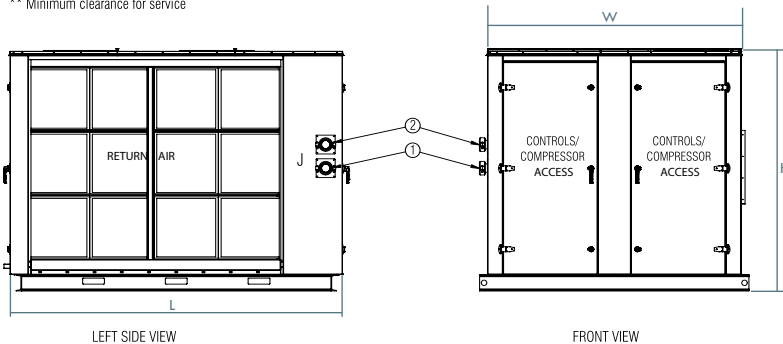
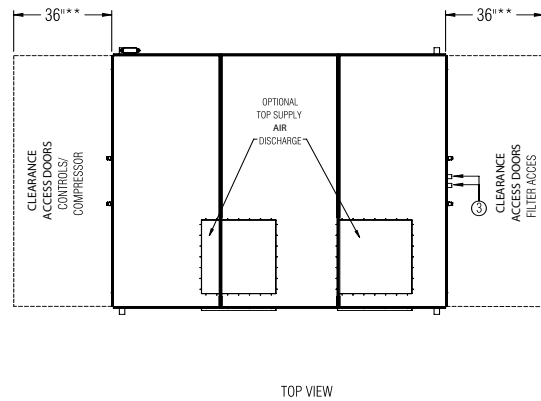

How do they work?

Varipak Standard Arrangement (VPS Model)

Heating and cooling coils are reversed for dehumidification.

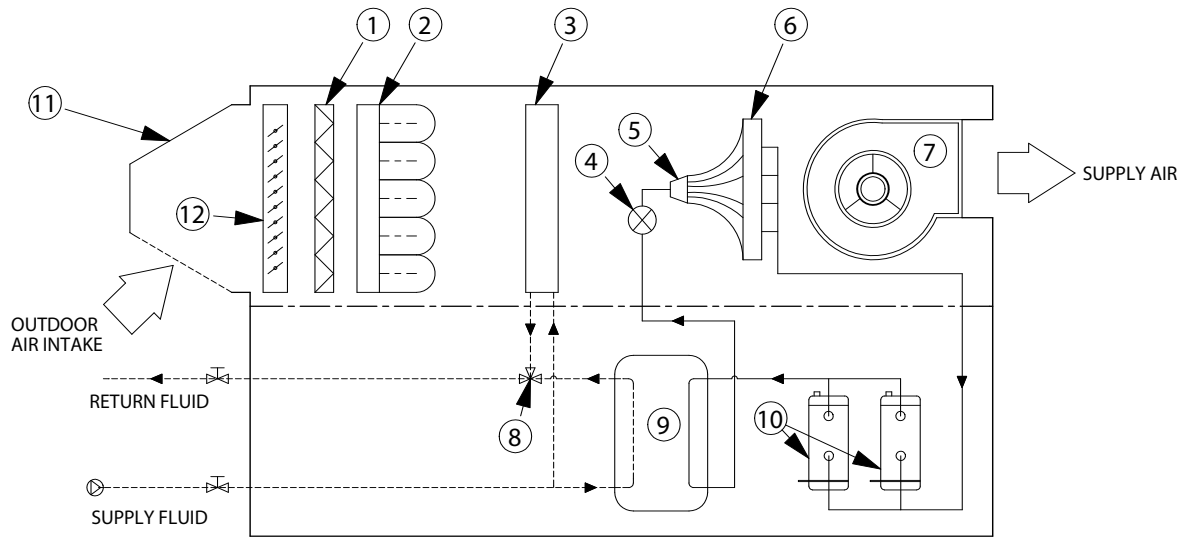

Legend			
1. Pre Filter	4. TX Valve	7. Supply Fan	10. Tandem Scroll Compressors
2. Bag Filter	5. Distributor	8. Diverting Valve	11. Intake Hood - Rooftop model only
3. Hydronic Heating Coil	6. DX Coil	9. Condensors	12. Intake Damper - Rooftop only

Varipak with Run Around Coil (VPE Model)

Reduces unit tonnage and power by up to 25%.

Available with Roof Mounted accessories.

Heating and cooling coils are reversed for dehumidification.

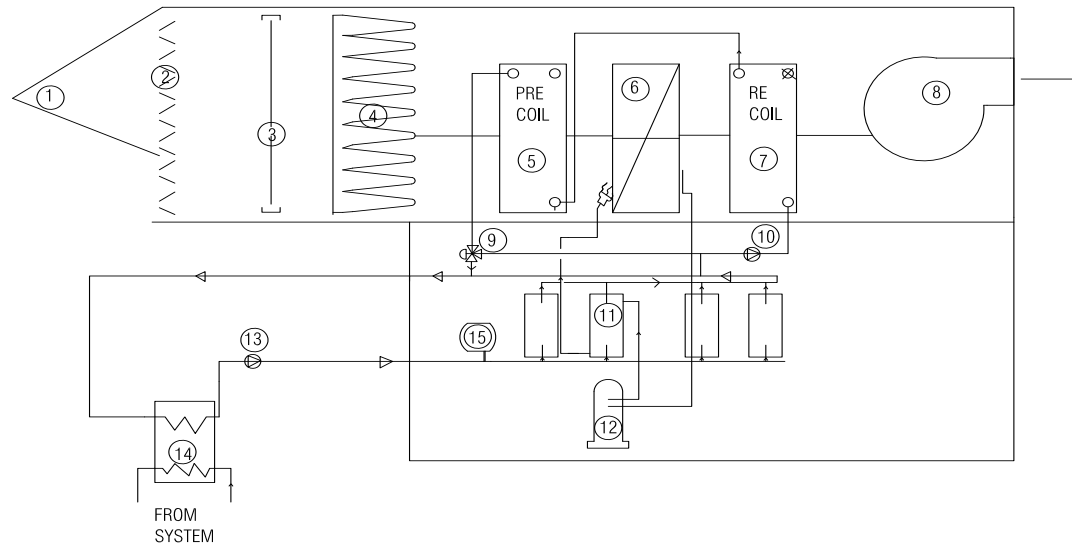

Legend			
1. Intake Hood (VPR only)	5. Glycol coil	9. Contol Valve	13. Pump*
2. Intake damper (VPR only)	6. DX coil	10. Pump	14. Heat Exchanger*
3. Pre filter	7. Glycol coil	11. Condenser	15. Expansion Tank*
4. Bag filters (MERV 11-13)	8. Supply Air fan	12. Compressor	*field supplied & mounted



Varipak with Exhaust Air Energy Recovery Wheel (VPW Model)

Heating and cooling coils are reversed for dehumidification.

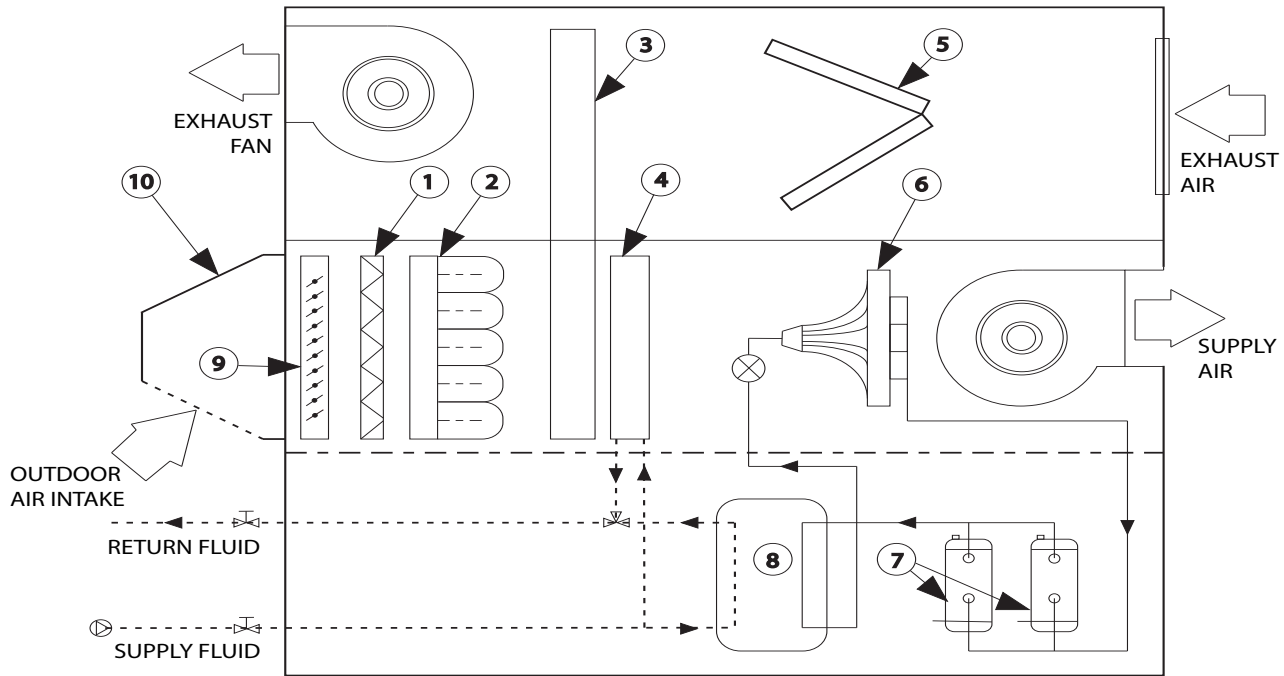

Legend			
1. 2" Pre filter	4. Hot Water heating coil	7. Compressors	10. Intake hood (rooftop unit)
2. Bag filters (MERV 11-13)	5. 2" Exhaust system Filters	8. Condenser	
3. Energy Recovery Wheel	6. DX coil	9. Intake damper (rooftop unit)	



Heat Recovery Wheel Option

Model	Supply Air CFM	Tonnage
VPW0	2000	5-20
VPW3	4000	5-28
VPW4	6000	10-30
VPW5	8000	10-40
VPW6	10000	10-50
VPW7	12000	10-60
VPW8	15000	10-60

Why and Where to Use the Varipak?

The ventilation air load of a building can represent 60% of the total energy consumed by the HVAC system. Placing this ventilation load on a common fluid loop with the remainder of the HVAC system can have significant energy benefits by achieving greater heat sharing capability.

The Varipak unit operates similarly to any other Bulldog unit.

It is a Make Up Air unit operating as a water cooled AC unit in cooling mode, and a hydronic coil for heating unit. It should be placed on a common fluid loop with the Bulldog units, although it's fluid would be glycol and decoupled from the building loop with a heat exchanger.

Basic Varipak Integration into a Bulldog System

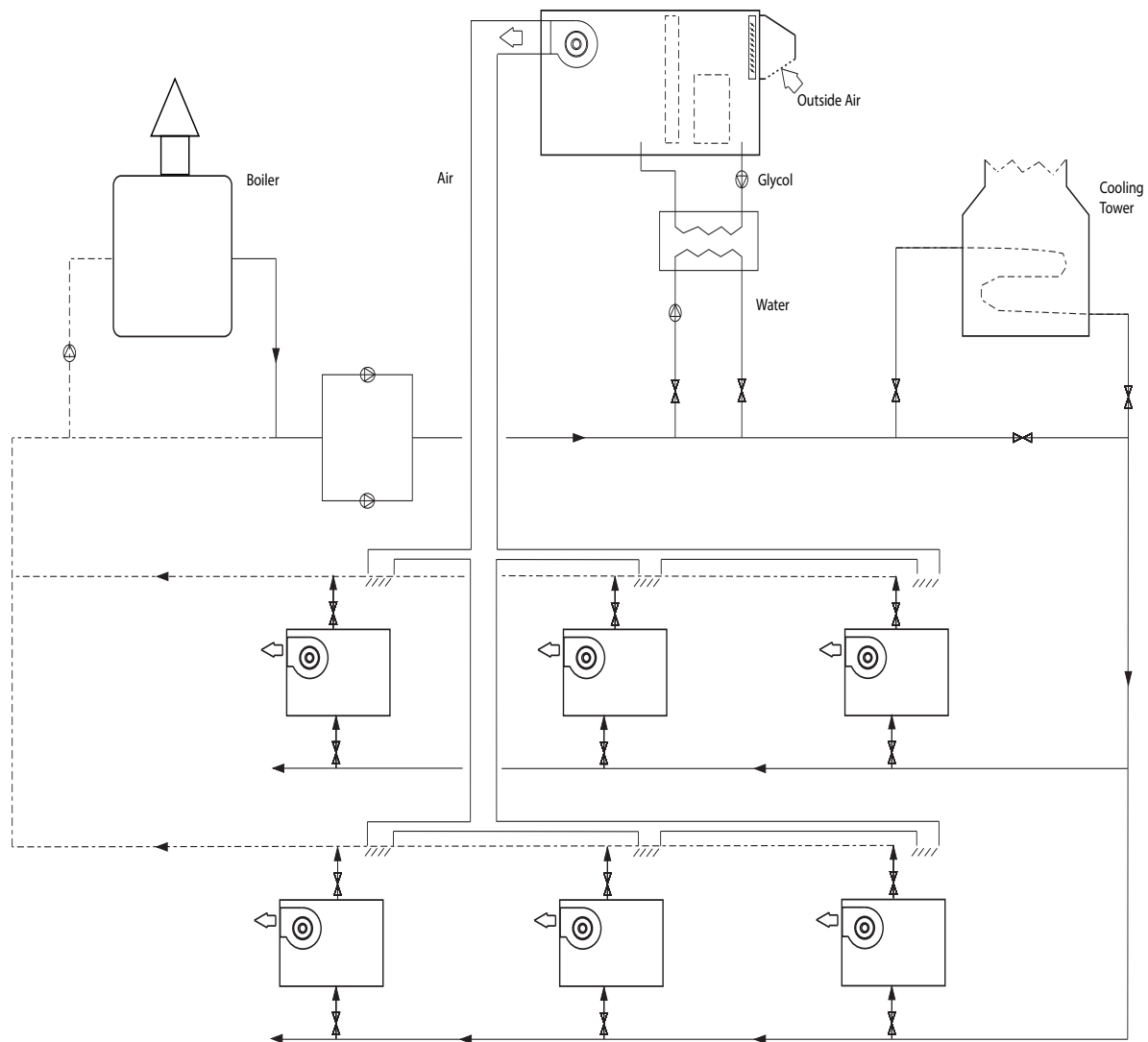



Generic Power/Controls Diagram

(Dehumidification unit shown)

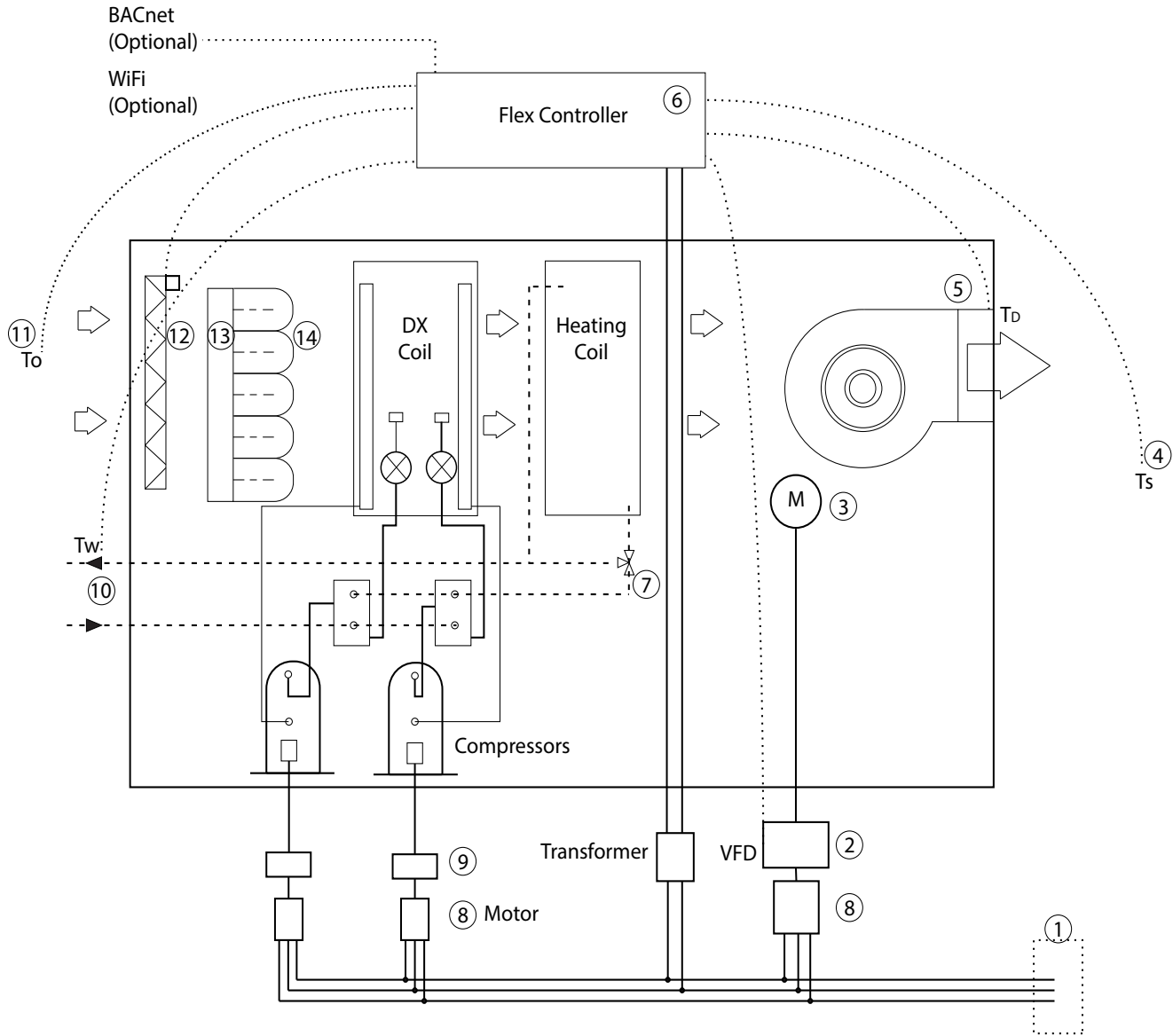

Legend			
1. Single point power connection disconnect switch by others	5. Discharge temperature (Td)	9. Contactors	13. 2" Pre filters
2. Fan VFD - if required	6. Stand alone Flex controller (unit mounted)	10. System Fluid Temperature Sensor (Tw)	14. Bag filters (MERV 11-13)
3. Fan motor	7. Modulating heat/reheat valve	11. Outside Air Temperature Sensor (To)	
4. Space sensor - resets discharge air temperature (Ts)	8. Motor protectors	12. Outside Air Damper with Actuator (standard on VPR)	

General Specification – Varipak Make Up Air Unit

PART 1 System Description

1.1 The HVAC system is based on the CGC Bulldog Heat Pump System. If the unit is to be exposed to intake temperatures lower than 35°F, an anti-freeze solution will be required throughout the unit. The fluid temperature rate of change (slope) will be adjusted during commissioning to best follow the building heating requirements.

1.2 Flow Systems - Units are supplied with a 3-way valve for continuous flow.

1.3 Model selection and performance shall be in accordance with the schedule on the drawings.

1.4 Each unit shall be pressure tested on both the refrigerant and fluid (water) circuits followed by a helium leak detection program for both circuits. All control functions shall be checked out. Individual units shall be self contained and complete when shipped from the factory. Some systems ship in sections - consult factory.

1.5 Units shall be safety certified and bear a seal of approval from one of UL/ULC/ETL or ESA.

1.6 Manufacturer shall warrant the parts only of each unit for a period of 12 months from the start-up date or 18 months from the unit shipment date whichever occurs first.

1.7 Commissioning of the CGC unit(s) shall be performed by a CGC trained technician. A commissioning report shall be provided by the commissioning technician for review and approval by the owner's representative.

1.8 Alternate proposals shall include consideration for equipment space requirements, pipe and equipment sizing, electrical installation impact, operation costs, sound implications and redesign fees.

PART 2 Mechanical Parts

2.1 Cabinet

2.1.1 The unit cabinet shall be constructed based on an integral frame and panel design with multiple full height hinged doors arranged for easy service access.

2.1.2 Major components shall be located out of the air path so as to avoid interrupting unit operation during routine service.

2.1.3 The cabinet shall be double skinned and fabricated with heavy gauge galvanized steel.

2.1.4 Exterior panels of the cabinet shall be double skinned galvanized steel and filled with 2 inch rigid foam (R10 value).

2.1.5 The cabinet base shall be structural steel channel frame with corner lifting points.

2.1.6 The exposed parts of the cabinet shall be complete with epoxy based powder coat baked enamel finish.

2.2 Blower and Motor

2.2.1 The blower shall be belt drive forward curved, DWDI centrifugal blower(s) operating at a speed not to exceed 85% of critical speed.

2.2.2 The blower bearing shall be of a pillow block type having provisions for lubrication. Extended lube lines shall be provided where nipples are inaccessible.

2.2.3 The blower shall be statically and dynamically balanced.

2.2.4 The blower motor shall be permanently lubricated.

2.2.5 The belt drive fan shall be sized for minimum 150% of the motor horsepower.

2.2.6 The fan shall have a fixed pitch sheave while the motor sheave shall be adjustable.

2.2.7 The blower motor shall be three phase with thermal overload protection.

2.2.8 The motor shall be easily accessible and removable for service.

2.2.9 The fan motor shall be totally enclosed fan cooled type.



2.3 Filter

Some options and sizes require an external filter box and shipped loose. Consult factory.

2.3.1 The filter section shall be an integral part of the system, located at the unit intake.

2.3.2 Pre-filters shall be 2" disposable type pleated 30/30 media filters with average efficiency of 30%.

2.3.3 After filters shall be a bag type Hi-Flo MERV 11-14 disposable media filters.

2.3.4 Filters shall be accessible through a hinged access door.

2.4 Hydronic Heating Loop

2.4.1 The refrigerant circuit shall not operate in heating mode.

2.4.2 The circuit shall include a glycol coil with an integral fully modulating three way valve.

2.4.3 The coil, header and control valve shall be integral and completely enclosed within the finished unit cabinet.

2.4.4 Heating coil shall be aluminum fin and copper tube construction rated to withstand 300 PSI working pressure.

PART 3 Refrigeration Parts

3.1 Refrigeration System

3.1.1 The refrigeration circuit shall be available for operation on non-ozone depleting R410a refrigerant.

3.1.2 The refrigeration circuit shall have the following components:

- Thermal Expansion Valve with external equalizer
- Filter dryer
- Refrigerant sight glass
- High pressure cut-out
- High pressure service port
- Low pressure cut-out
- Low pressure service port

3.1.3 The service ports shall be located to facilitate field service with unit in place.

3.1.4 All refrigerant piping shall be of type ACR copper pipe.

3.1.5 The refrigerant circuit and components shall be factory assembled, sealed, leak tested, and charged with refrigerant. Adjustment of the charge may be required as part of commissioning process for supply and return and two 1-1/2" condensate drains.

3.1.6 The sealed refrigerant circuit shall be certified for 600 PSIG working pressure.

3.2 Compressor

3.2.1 The compressors shall be high efficiency sealed hermetic scroll types.

3.2.2 The compressor shall be externally isolated on rubber mounts and connected to refrigerant circuit with floating piping to minimize sound transmission.

3.2.3 The Compressor motor shall have integral thermal overload protection.

3.2.4 The compressor shall not operate in the heating mode.

3.2.5 The Compressor shall be provided with a 5 minute restart delay to avoid compressor short cycling and low pressure lockout.

3.3 Direct Expansion Evaporator Coil

3.3.1 The Refrigerant to air heat exchanger shall be aluminum fin and copper tube construction rated to withstand 300 PSI refrigerant working pressure.

3.3.2 A high corrosion resistant condensate drain pan shall be provided under the coil.

3.4 Water Cooled Condenser Module

3.4.1 The condenser(s) shall be high efficiency refrigerant-to-water tube in shell design. Tube shall be made of smooth interior wall copper, minimum 5/8" diameter for clog free operation. Outer shell shall be steel rated to withstand 600 PSI refrigerant working pressure and 450 PSI water pressure.

3.4.2 The fluid connections for size '0' shall be female pipe thread extended to be flush with the cabinet exterior. Condensate drain connection shall be 3/4". All other sizes have groove mechanical connections. Contractor shall supply and install minimum 3" trap and connect to drain to overcome ISP+1".

PART 4 Control System

4.1 System

4.1.1 The unit shall be equipped with a micro-processor-based digital controller. An outside air temperature sensor (mounted by the contractor) will be used to switch the unit between heating and cooling modes. Heating is typically activated when the outside air temperature drops below 64°F, and cooling is typically activated when the outside air temperature rises above 70°F. Control algorithms shall be designed to receive a signal from a space temperature sensor (mounted by the contractor) located in the conditioned area. In heating mode this space temperature signal will be fed through a PID module that will control the discharge air temperature using a modulating heating valve. In cooling mode this space temperature signal will be fed through a separate PID module that will control compressor staging.

4.1.2 The controller shall monitor the following:

- Outside air temperature
- Supply air temperature
- Fluid (glycol) leaving temperature
- Space temperature
- High refrigerant pressure
- Low refrigerant pressure

4.1.3 The controller shall control the following:

- Outside air damper (provided by others on indoor units)
- Supply fan (VFD if specified)
- Modulating heating valve
- Compressor operation

4.1.4 Operational safeties:

- Outside air temperature
- Open heating valve 50% during shutdown
- Low temperature shutdown
- Staged start up of all functions
- Anti recycle operation of all components
- High pressure and low pressure refrigerant safeties

4.1.5 The control board shall have built in control diagnostic function.

4.1.6 The controller is available to communicate with the BAS using Modbus RTU. For all other BAS languages, including BACnet, consult factory.

4.2 Alarms

4.2.1 The standard Control Panel shall have the following standard alarms:

- Low Coil Temperature
- High Leaving Water Temperature
- Low Discharge Air Temperature
- Low Refrigerant Pressure
- High Refrigerant Pressure
- High Condensate Level (OPTIONAL)

Part 5 Accessories

5.1.1 (OPTIONAL) Roof curb for outdoor mounting (NOTE: this option not available on VPA models)

5.1.2 (OPTIONAL) Intake damper. Damper shall be extruded aluminum with shut off sealing parallel blades and complete with spring return actuator. Standard on VPR.

5.1.3 (OPTIONAL) Variable frequency fan motor drive.

5.1.4 (OPTIONAL) Vertical up discharge.

5.1.5 (OPTIONAL) Refrigerant based exhaust air heat recovery section.

5.1.6 (OPTIONAL) VPW model - Thermal Wheel Recovery.



Available Options

Extend 5 year compressor warranty	This provides an extended compressor only warranty for an additional 4 years. Shipping costs are not included. (parts only)
Roof Curb for outdoor mounting	Not available for indoor models. The rooftop model frame has removeable covers for the fork lift holes.
Intake damper	Intake damper will be extruded aluminum with shut off sealing parallel blades and complete with spring return actuator. Not available for indoor models.
Tandem scroll set	This provides improved part load efficiency using tandem compressors with only one refrigeration circuit but in two stages. The improvement in efficiency occurs when the system operates one compressor with the full size evaporator and condenser.
Hot gas bypass	This provides hot gas bypass for low load situations when partial cooling is required but the resulting compressor operation would create low pressure issues. Hot gas bypass injects hot refrigerant gas directly into the direct expansion distributor inducing a false load on the evaporator, warming it and increasing the suction pressure. Use this option when a two stage compressor is still not enough turn down for the cooling requirements.
Condensate overflow protection	This will provide a solid state condensate sensor that will terminate cooling operation if the drain pan level rises too high. An alarm will be available to connect to the alarm output.
Mount third party DDC	Select this option to have third party DDC controllers mounted on or in the unit. Included is a box to hold the controller and isolation transformer if there is no available space. Alarm signal will be provided to the DDC controller. The controller is used to transmit calls and lockout signals to the onboard heat pump controller.
Variable frequency fan motor drive (VFD)	Provides adjustment for fan speed for site air balancing. May be used for energy savings. Consult factory.
Pump or valve flow control signal	This provides a 24VAC signal for the control of a valve or a pump to provide flow only during a heating or cooling call. Valve and pump provided by others.
Demand flow control	This option is required for variable volume pumping systems. An auto flow valve is an automatic throttling valve that controls the amount of water through the unit when it is either heating or cooling.
Auto flow limiting control	This provides an autoflow valve to our standard unit with a single 3-way valve. The autoflow valve is an automatic throttling valve that controls the amount of water through the unit when it is either heating or cooling.
High capacity heating coil	This provides a heating coil with an additional row of increased heating capacity. Consult factory.
Dehumidification control with demand flow	This option provides the ability of the unit to cool/dehumidify and then reheat the discharge air for humidity control. Space sensor incorporates a humidity sensor and Varipak controls to maintain RH in cooling season only.
Sized fan motor	This provides an oversized or undersized motor.
Vertical up discharge	Provides supply air discharge out the top of the Varipak.
Unit mounted Flex controller with display	This provides a Modbus RTU compatible controller, in place of the standard controller, to provide DDC to the building automation system. The controller is used to transmit calls and lockout signals to the onboard unit controller.



Corporate

150 Britannia Rd East, Unit 1
Mississauga, Ontario, Canada
L4Z 2A4
1-905-568-1888

www.cgc-group.com