

- ① Water Outlet, 1/2" FPT
- ② Water Inlet, 1/2" FPT
- ③ Condensate Drain, 3/4" FPT
- ④ High Voltage Access, 7/8"
- ⑤ Low Voltage Access, 7/8"

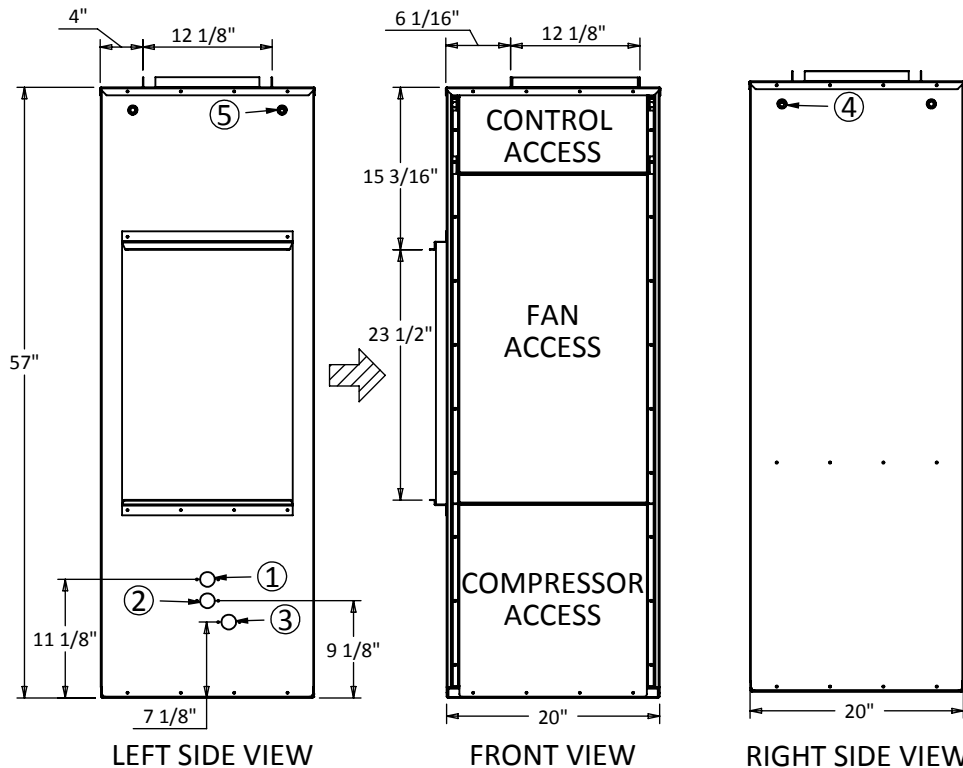
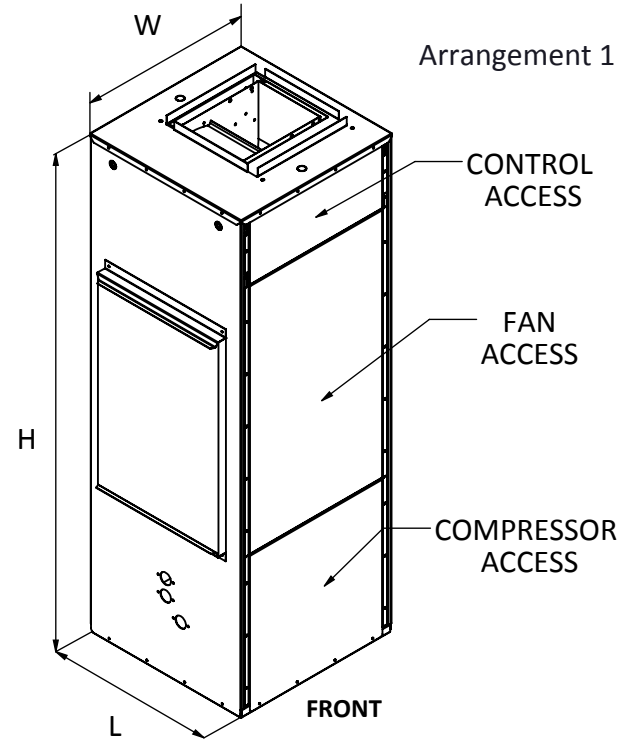

PHYSICAL DATA [in]						RECOMMENDED MIN. SERVICE CLEARANCE		
W	L	H	SUP. AIR W x H	RET. AIR W x H	UNIT WT	A	B	C
20	20	57	12.13 x 12.13	15.5 x 24	240Lb	2	36**	6*

- \* Non- ducted return air only
- \*\* Recommended for closet door open (Closed door 2")

**REMARKS:**

1. Pleated disposable filter included. (16" x 25" x 1")
2. Right side electrical access available.
3. Left return unit (ARR. 1) , right return unit (ARR. 2).
4. Water piping on same side as filter access.

BULLDOG HEAT PUMP		THE INFORMATION CONTAINED IN THIS DRAWING IS THE SOLE PROPERTY OF CGG GROUP. ANY REPRODUCTION IN PART OR AS A WHOLE WITHOUT THE WRITTEN PERMISSION OF CGG GROUP IS PROHIBITED.	NAME	DATE (MM/DD/YYYY)	<b>DIMENSIONAL DATA</b>
DRAWN	K.F		06/24/2013		
CHECKED					<b>BULLDOG SpaceKeeper Vertical Heat Pump Models SKV-020 through SKV-036</b>
ENG APPR.	F.A.L		01/09/2015		
REV.	AG		08/11/2015		
Q.A.	FL		08/11/2015		
COMMENTS:					DO NOT SCALE DRAWING
UNLESS OTHERWISE SPECIFIED: DIMENSIONS ARE IN INCHES TOLERANCES UNLESS OTHERWISE NOTED ARE:					SIZE <b>A</b> DWG. NO. <b>SKV020-036</b> REV. <b>A</b>
FRACTIONAL ± 1/16"					SCALE: NTS
ANGULAR ± 0.5°					WEIGHT:
X: ± .1"					SHEET 1 OF 1
XX: ± .06"					
XXX: ± .032"					
XXXX: ± .0050"					