

- ① Water Outlet, 1/2" FPT
- ② Water Inlet, 1/2" FPT
- ③ Condensate Drain, 3/4" FPT
- ④ High Voltage Access, 7/8"
- ⑤ Low Voltage Access, 7/8"

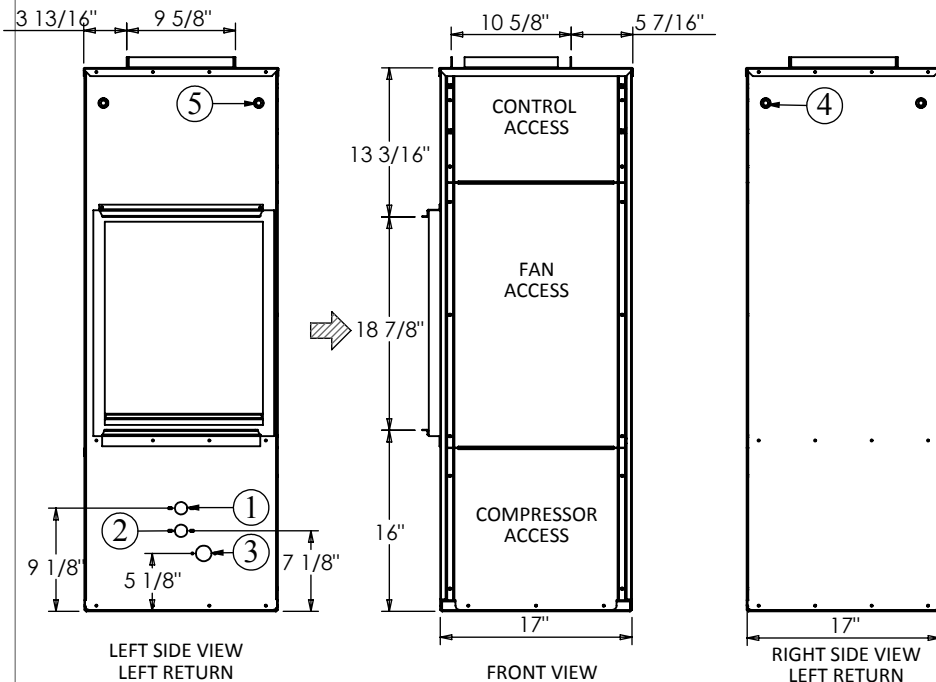
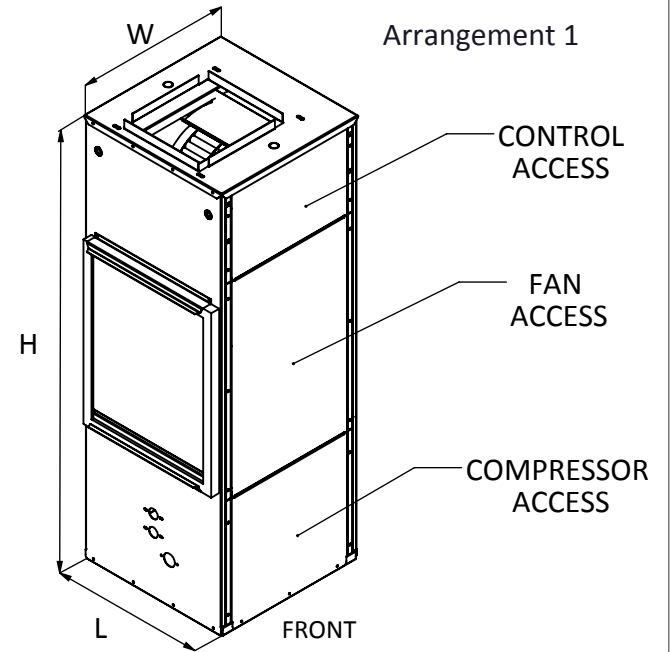

PHYSICAL DATA [in]						RECOMMENDED MIN. SERVICE CLEARANCE		
W	L	H	SUP. AIR W x H	RET. AIR W x H	UNIT WT	A	B	C
17	17	48	10.5 x 9.5	14 x 19	175Lb	2	36**	6*

* Non- ducted return air only

** Recommended for closet door open (Door closed 2")

REMARKS:

- Pleated disposable filter included. (16" x 20" x 1")
- Right side electrical access available.
- Left return unit (ARR. 1), right return unit (ARR. 2).
- Water piping on same side as filter access.

BULLDOG HEAT PUMP		NAME	DATE	DIMENSIONAL DATA
THE INFORMATION CONTAINED IN THIS DRAWING IS THE SOLE PROPERTY OF CGC GROUP. ANY PRODUCTION IN PART OR AS A WHOLE WITHOUT THE WRITTEN PERMISSION OF CGC GROUP IS PROHIBITED.		K.F	06/24/2013	
UNLESS OTHERWISE SPECIFIED: DIMENSIONS ARE IN INCHES TOLERANCES UNLESS OTHERWISE NOTED ARE: FRACTIONAL ± 1/16" ANGULAR ± 0.5° X: ± .1" XX: ± .06" XXX: ± .032" XXXX: ± .0050"		CHECKED		BULLDOG SpaceKeeper Vertical Heat Pump Models SKV-008 through SKV-018
		ENG APPR.	F.A.L 06/24/2013	
		REV.	AG 08/14/2015	
		Q.A.	F.A.L 08/14/2015	
		COMMENTS:		SIZE
		DO NOT SCALE DRAWING		DWG. NO.
				REV.
				A
		SCALE: NTS	WEIGHT:	SHEET 1 OF 1