

Arr. 1 Left Return, Right Supply

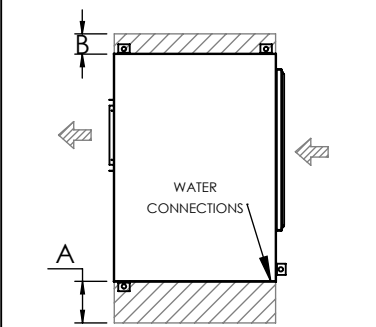

Arr. 2 Right Return, Left Supply

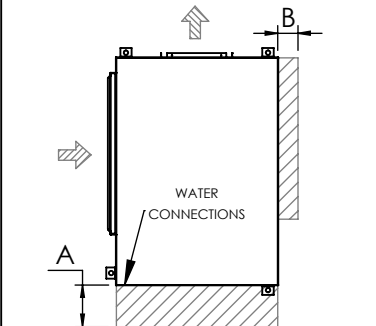

Arr. 3 Left Return, Back Supply

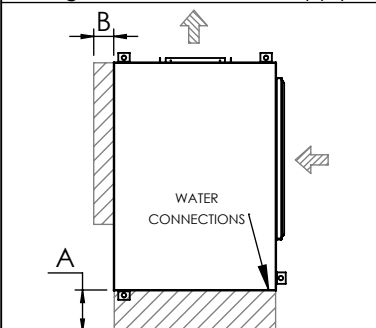

Arr. 4 Right Return, Back Supply

LEGEND:

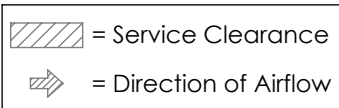

- ① Water Inlet, 3/4" FPT
- ② Water Outlet, 3/4" FPT
- ③ Condensate Drain, 3/4"
- ④ High Voltage Access, 1 1/8" Knockout
- ⑤ Low Voltage Access, 7/8" Knockout

REMARKS:

- i) Two disposable fiberglass filter included. (16" x 20" x 1")
- ii) Rubber in shear isolation included.
- iii) Arrangement 1 is shown to provide essential dimensions.
- iv) Recommended position for hanging clips is shown.
- v)* Water connections are positioned on the same side as the return air.

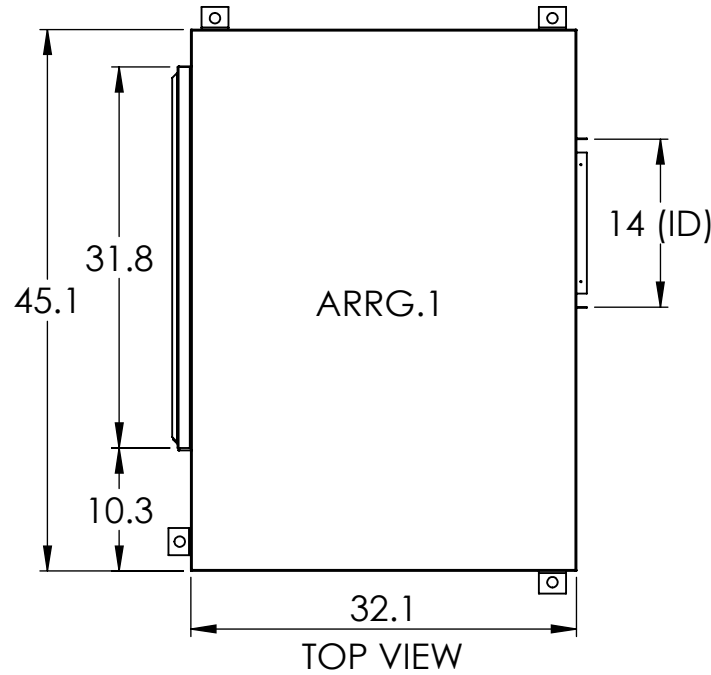

TOP VIEW

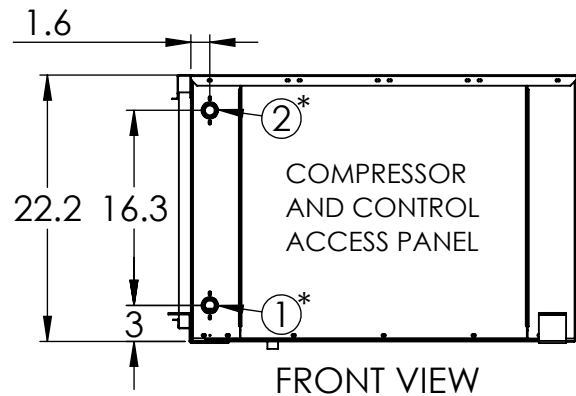

FRONT VIEW

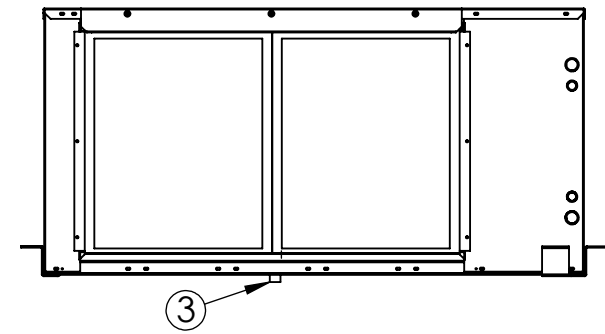

LH SIDE VIEW

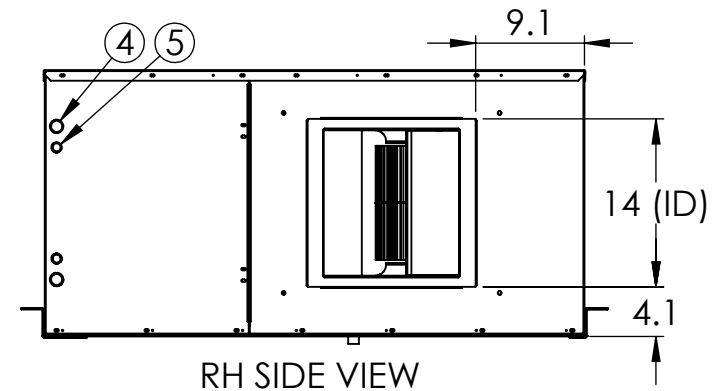

RH SIDE VIEW

PHYSICAL DATA [in]					MIN. SERVICE CLEARANCE REQUIRED	
W	L	H	SUP. AIR (W x H)	RET. AIR (W x H)	UNIT WT (lbs)	
32	45	22	14 x 14	32 x 18	375	
					A	B
					30	18

<p>THE INFORMATION CONTAINED IN THIS DRAWING IS THE SOLE PROPERTY OF CGC Group. ANY REPRODUCTION IN PART OR AS A WHOLE WITHOUT THE WRITTEN PERMISSION OF CGC Group IS PROHIBITED.</p> <p>UNLESS OTHERWISE SPECIFIED: DIMENSIONS ARE IN INCHES</p> <p>COLEGANES UNLESS OTHERWISE NOTED ARE:</p> <p>FRACTIONAL = 1/16" ANGULAR = 0.5° X = 1° XX = 0.01" XXX = 0.005" XXXX = 0.0025"</p>	NAME: (MM/DD/YYYY):	DATE: 7/11/2018	DIMENSIONAL DATA BULLDOG SpaceKeeper Horizontal Heat Pump Models SKH-042 through SKH-060 DWG. NO. SKH 042-060 SCALE: NTS WEIGHT: 375 lbs SHEET 1 OF 6
	DRAWN: MRH	CHECKED: AJM	
	MATERIAL:	FINISH:	