

LEGEND:

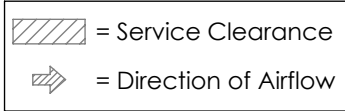

- ① Water Inlet, 1/2" FPT
 - ② Water Outlet, 1/2" FPT
 - ③ Condensate Drain, 3/4"
 - ④ High Voltage Access, 1 1/8" Knockout
 - ⑤ Low Voltage Access, 7/8" Knockout
- (located on opposite side of unit as High Voltage Access)

REMARKS:

- i) One disposable fiberglass filter included. (14" x 20" x 1")
- ii) Rubber in shear isolation included.
- iii) Arrangement 1 is shown to provide essential dimensions.
- iv) Recommended position for hanging clips is shown.
- v)* Water connections are positioned on the same side as the return air.

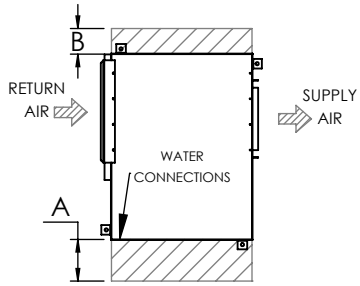

Arr. 1 Left Return, Right Supply

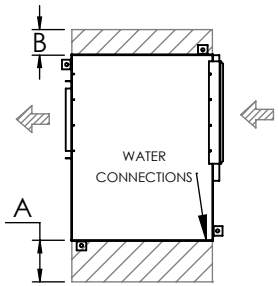

Arr. 2 Right Return, Left Supply

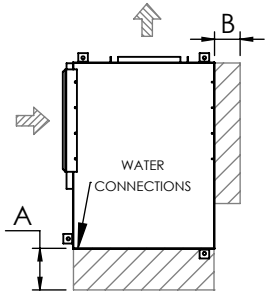

Arr. 3 Left Return, Back Supply

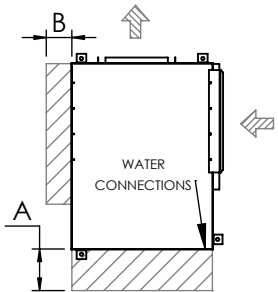

Arr. 4 Right Return, Back Supply

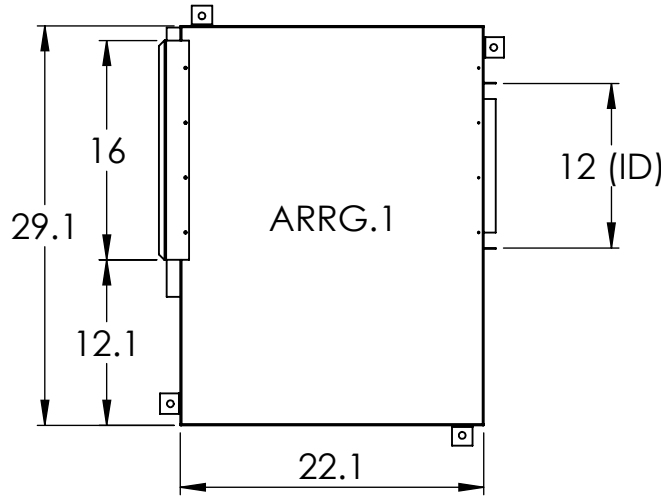

TOP VIEW

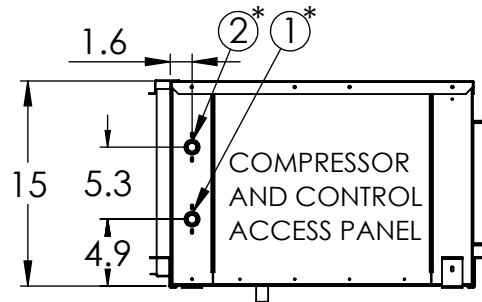

FRONT VIEW

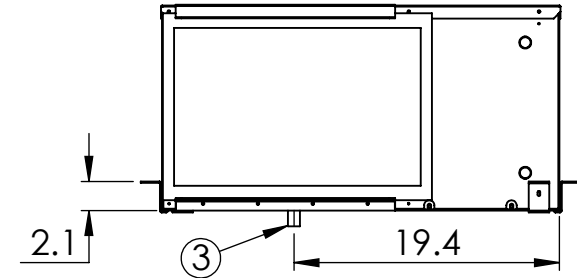

LH SIDE VIEW

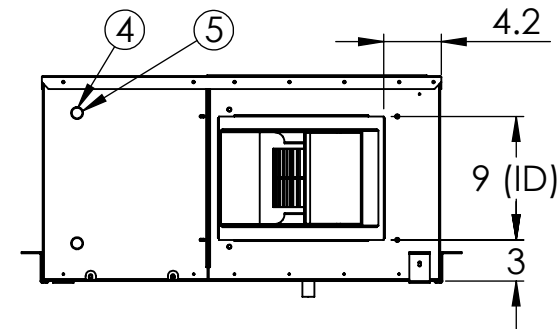

RH SIDE VIEW

PHYSICAL DATA [in]						MIN. SERVICE CLEARANCE REQUIRED	
W	L	H	SUP. AIR (W x H)	RET. AIR (W x H)	UNIT WT (lbs)	A	B
22	29	15	12 x 9	16 x 13	160	30	18

CGC GROUP

THE INFORMATION CONTAINED IN THIS DRAWING IS THE SOLE PROPERTY OF CGC Group. ANY REPRODUCTION IN PART OR AS A WHOLE WITHOUT THE WRITTEN PERMISSION OF CGC Group IS PROHIBITED.

UNLESS OTHERWISE SPECIFIED: DIMENSIONS ARE IN INCHES.

CO. LEANES UNLESS OTHERWISE NOTED. SEE FRACTIONAL: = 1/16" ANGULAR: = 0.5° X: = 1° XX: = 0.01" XXX: = 0.005" XXXX: = 0.0025"

NAME:	DATE (MM/DD/YYYY):
DRAWN: MRH	7/11/2018
CHECKED: AJM	7/11/2018
MATERIAL:	
FINISH:	

DIMENSIONAL DATA		
BULLDOG SpaceKeeper Horizontal Heat Pump Models SKH-008 through SKH-018		
SIZE	DWG. NO.	REV.:
A	SKH 008-018	A
SCALE: NTS	WEIGHT: 160 lbs	SHEET 1 OF 6