

**REMARKS:**

- One Pleated Disposable Filter Included (16" x 20" x 1")
- Right Side Electrical Access Available
- Water Piping on Same Side as Filter Access
- Left Return Unit (ARRG. 1), Right Return Unit (ARRG. 2).

- A - Water Outlet, 3/4" FPT
- B - Water Inlet, 3/4" FPT
- C - Condensate Drain, 3/4" FPT
- D - High Voltage Access, 7/8"
- E - Low Voltage Access, 7/8"

THE INFORMATION CONTAINED IN THIS DRAWING IS THE SOLE PROPERTY OF CGC Group. ANY REPRODUCTION IN PART OR AS A WHOLE WITHOUT THE WRITTEN PERMISSION OF CGC Group IS PROHIBITED.



PAGE: 1 of 3	
PRODUCT FAMILY:	SKV 008-018
PRODUCT REVISION(S):	L
DATE(MM/DD/YYYY):	01/09/2026 REV: A
DESCRIPTION:	Standard Submittal Drawing for SpaceKeeper Vertical Stacked Hybrid R454B

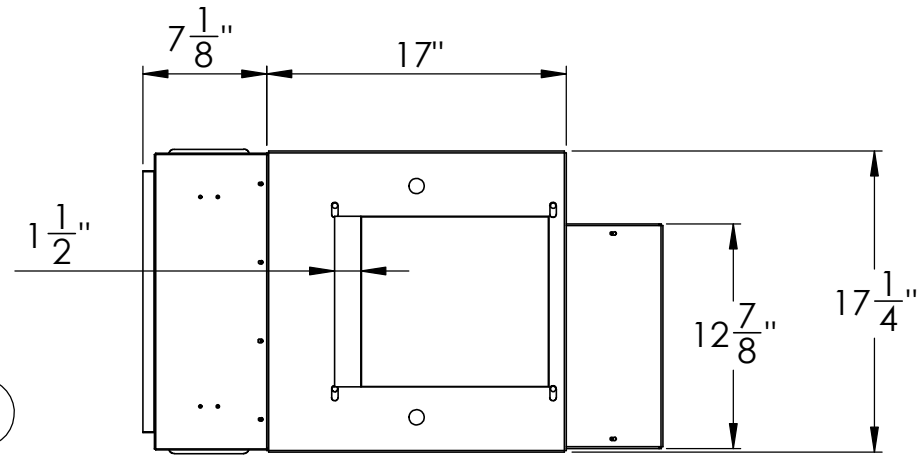
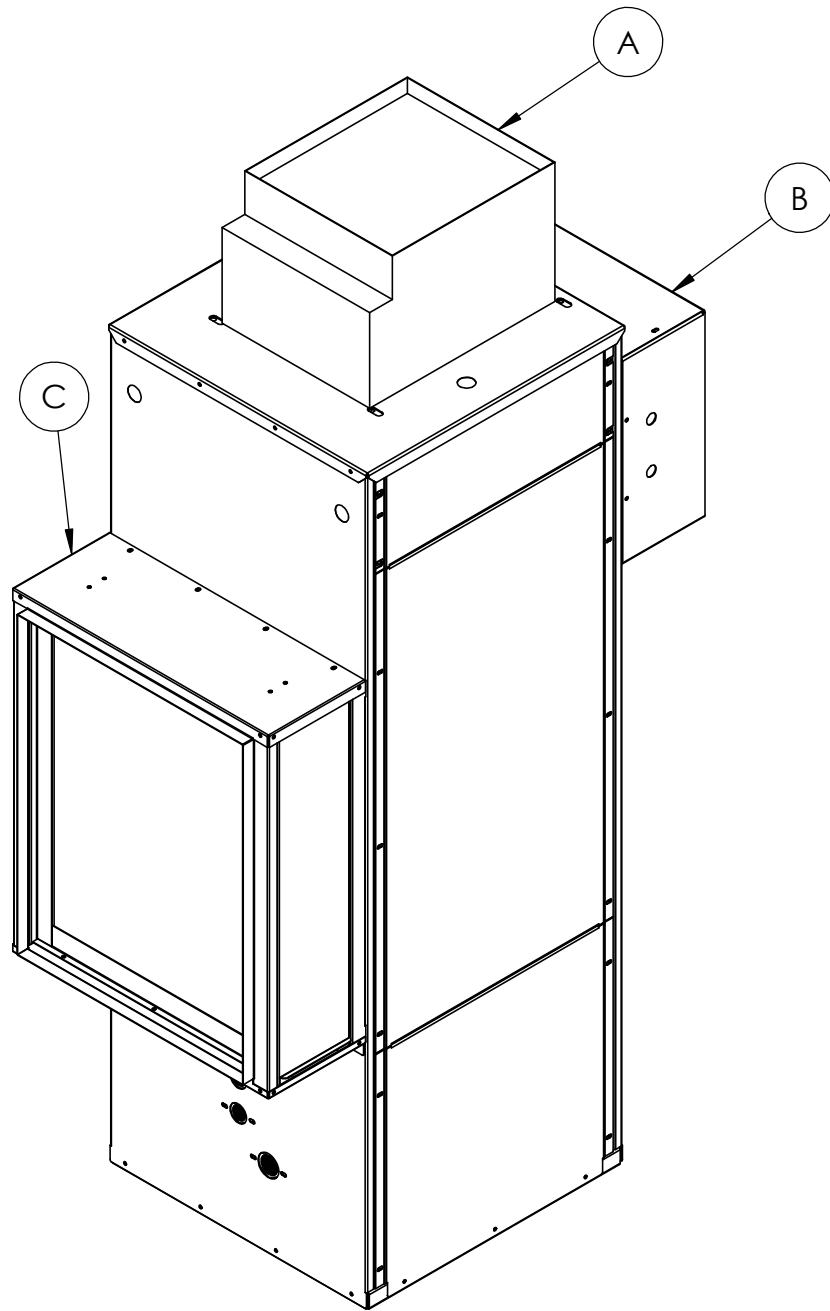

TOP VIEW

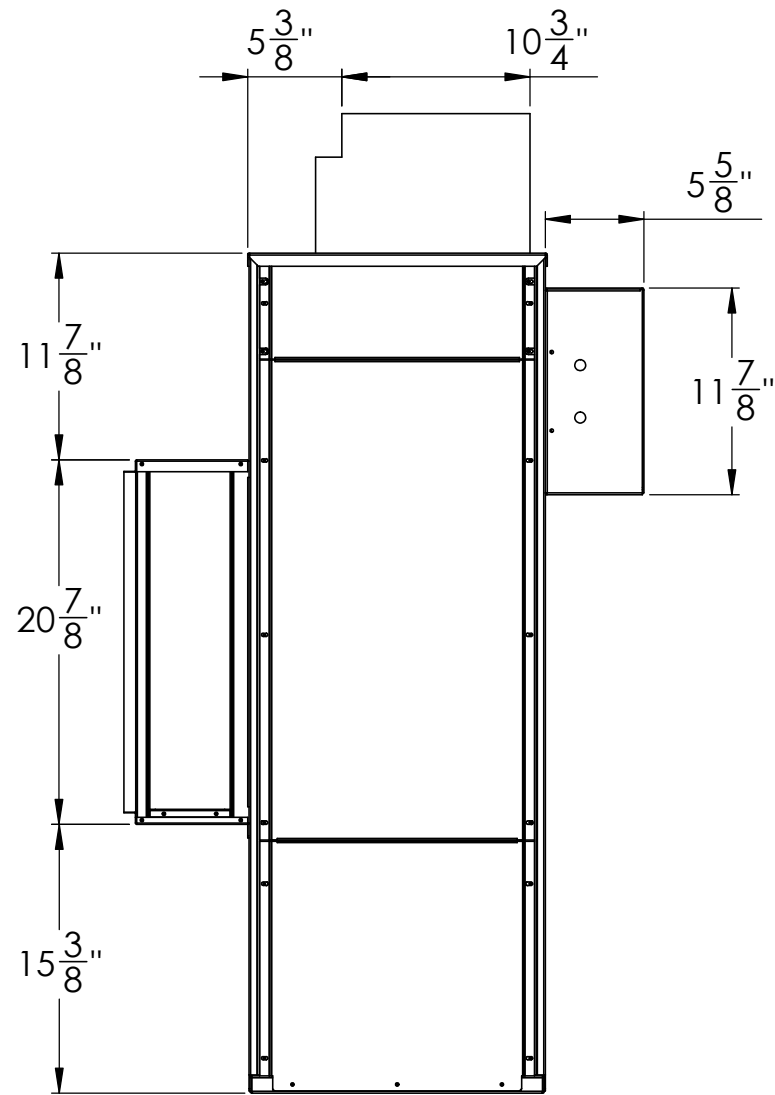

FRONT VIEW

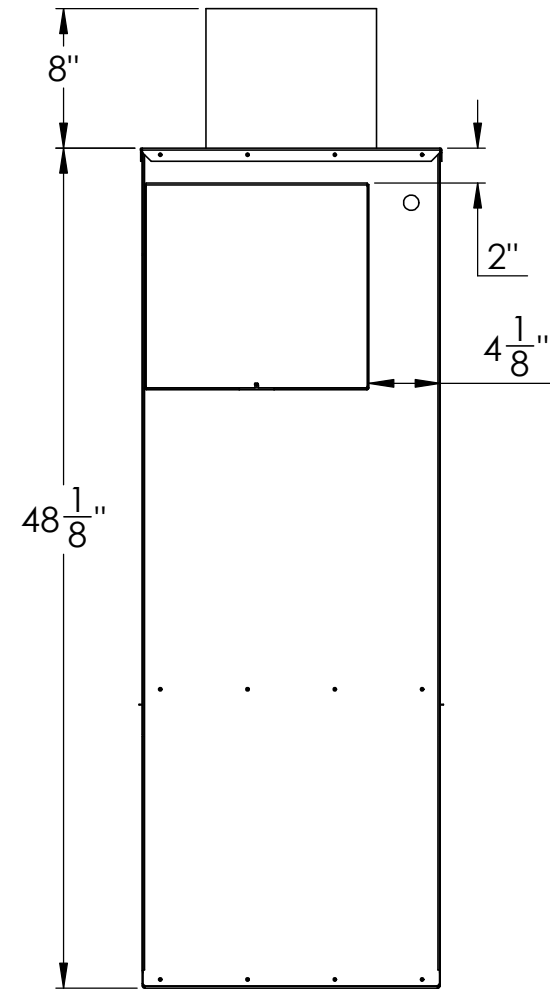

RH SIDE VIEW

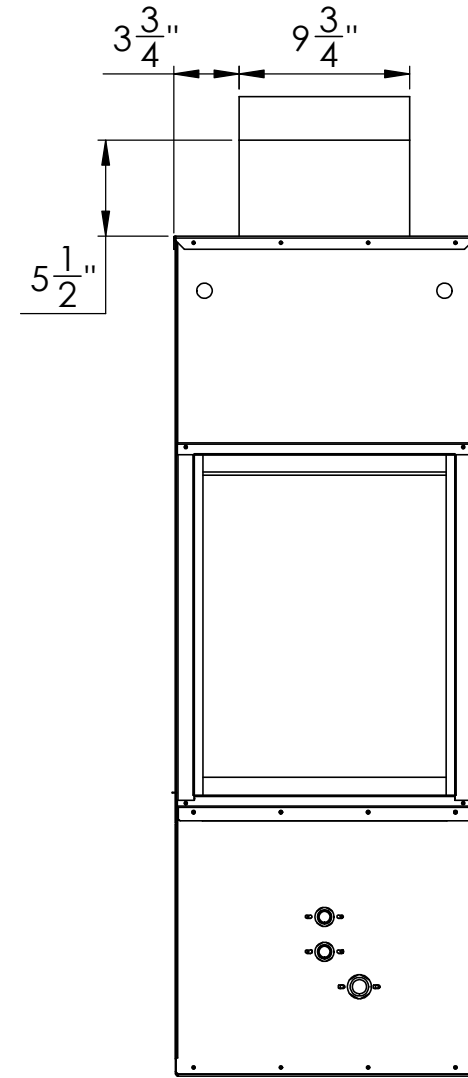

LH SIDE VIEW

NOTE: Dimensions are typical Between all Arrangements

- (A) Optional Electric Heater
- (B) Optional Add on Box
- (C) Optional Filter Box

THE INFORMATION CONTAINED IN THIS DRAWING IS THE SOLE PROPERTY OF CGC Group. ANY REPRODUCTION IN PART OR AS A WHOLE WITHOUT THE WRITTEN PERMISSION OF CGC Group IS PROHIBITED.



PAGE: 2 of 3	
PRODUCT FAMILY:	SKV 008-018
PRODUCT REVISION(S):	L
DATE(MM/DD/YYYY):	01/09/2026 REV: A
DESCRIPTION:	Standard Submittal Drawing for SpaceKeeper Vertical Stacked Hybrid R454B

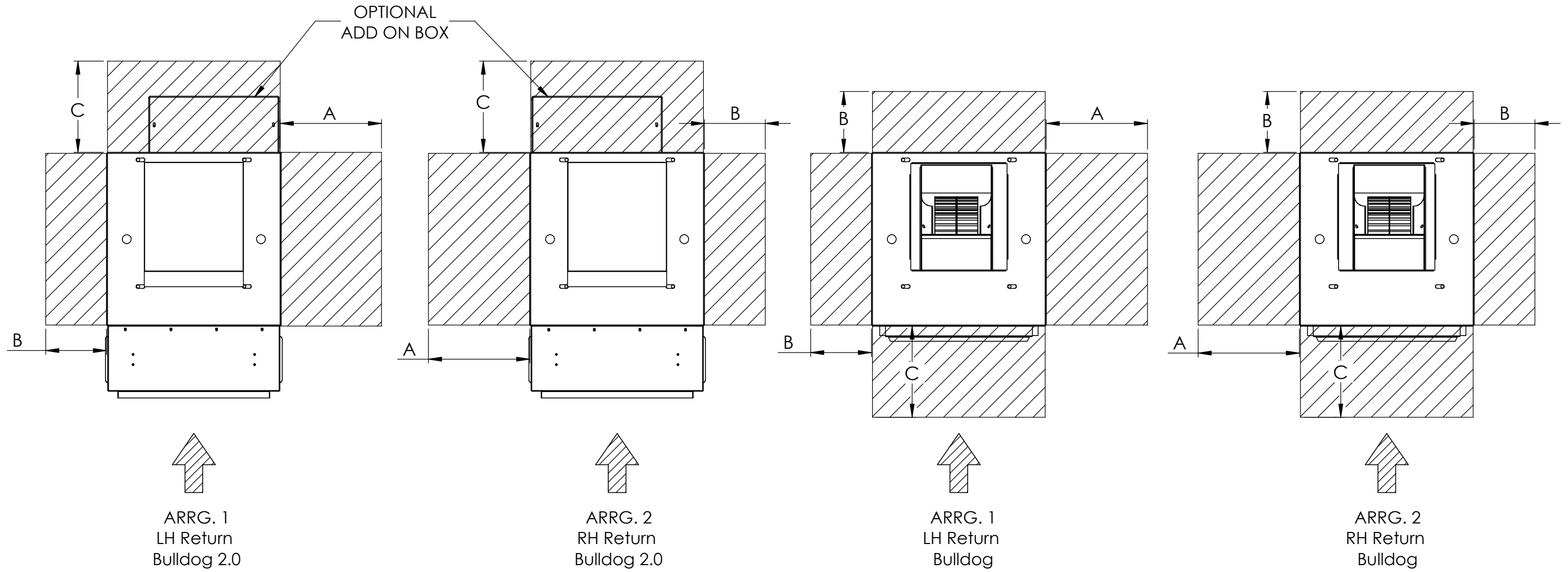

LEGEND:

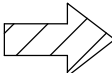
	= SERVICE CLEARANCE	Clearance Dimensions	
		A	30"
		B	18"
		C	20"
	= DIRECTION OF RETURN AIRFLOW		

THE INFORMATION CONTAINED IN THIS DRAWING IS THE SOLE PROPERTY OF CGC Group. ANY REPRODUCTION IN PART OR AS A WHOLE WITHOUT THE WRITTEN PERMISSION OF CGC Group IS PROHIBITED.



PAGE: 3 of 3	
PRODUCT FAMILY:	SKV 008-018
PRODUCT REVISION(S):	L
DATE(MM/DD/YYYY):	01/09/2026 REV: A
DESCRIPTION:	Standard Submittal Drawing for SpaceKeeper Vertical Stacked Hybrid R454B