

LEGEND:

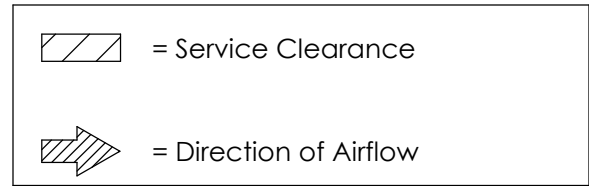

1. Water Inlet, 1/2" FPT
2. Water Outlet, 1/2" FPT
3. Condensate Drain, 3/4"
4. Low Voltage Access, 7/8" Knockout
5. Control Panel Cover

REMARKS:

- i) One Disposable Fiberglass Filter Included. (12" x 20" x 1")
- ii) For Proper Services of the Refrigerant circuit, the Unit should be Lowered to Ground Level and the Top Panel Should be Removed.
- iii) Arrangement 1 is Shown to Provide Essential Dimensions.
- iv) This Unit is a Blow Through Unit Instead of CGC Group's Standard Draw Through Unit.
- v) Drain Pan is Under Positive Pressure, Trap not Required

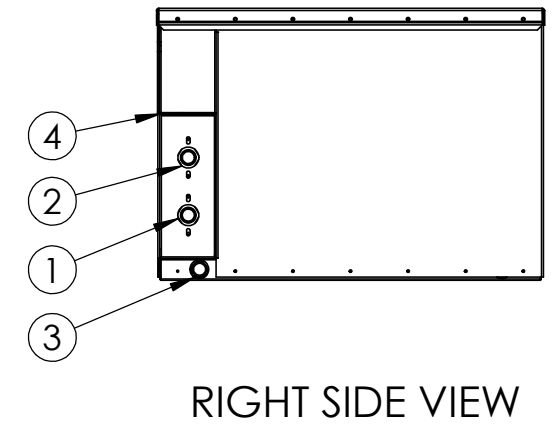
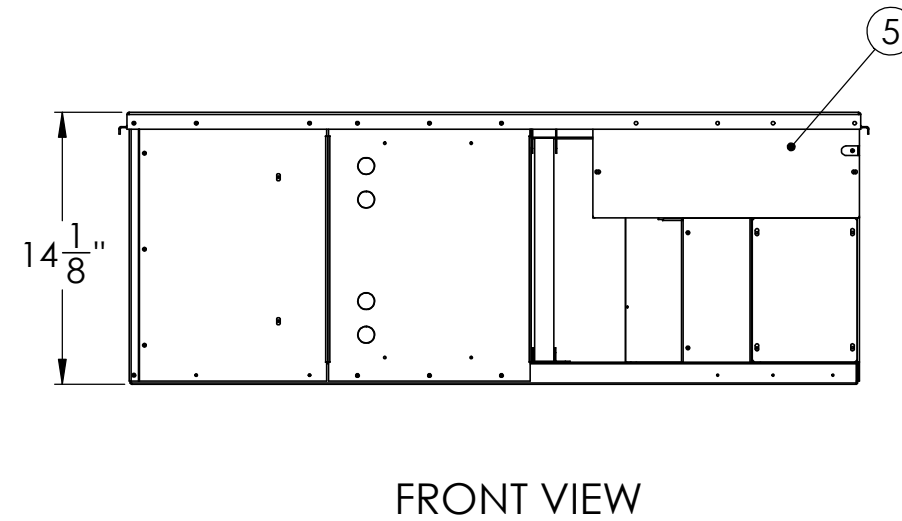
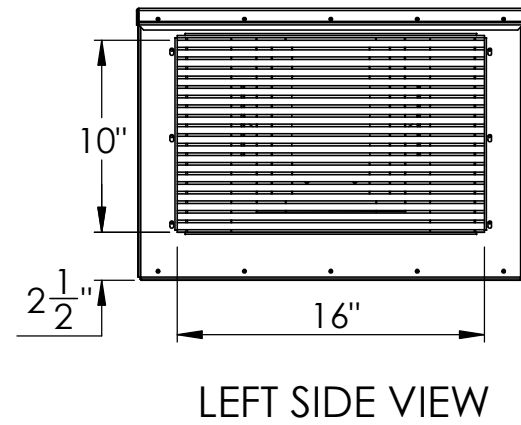
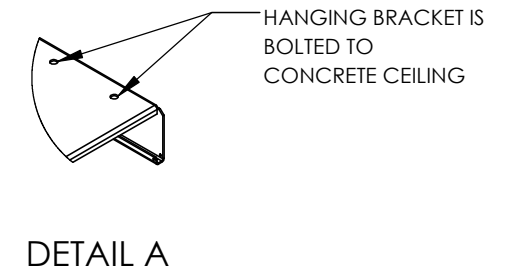
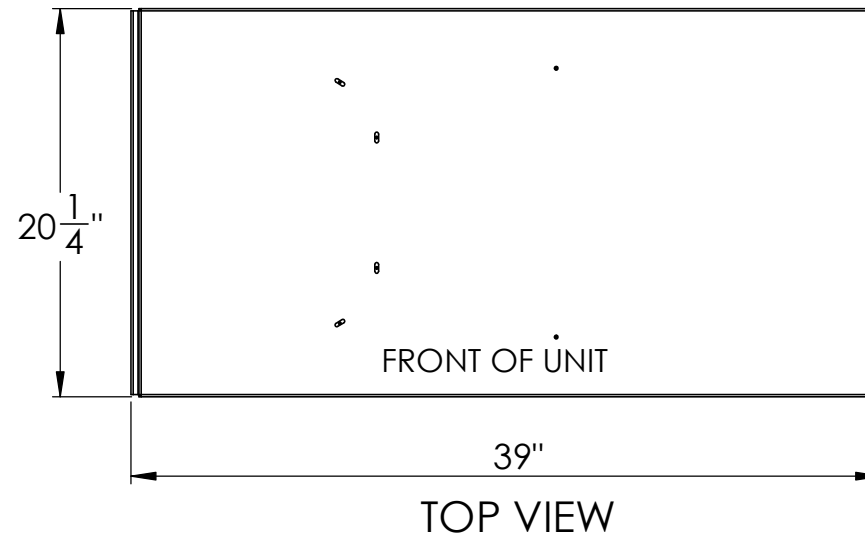
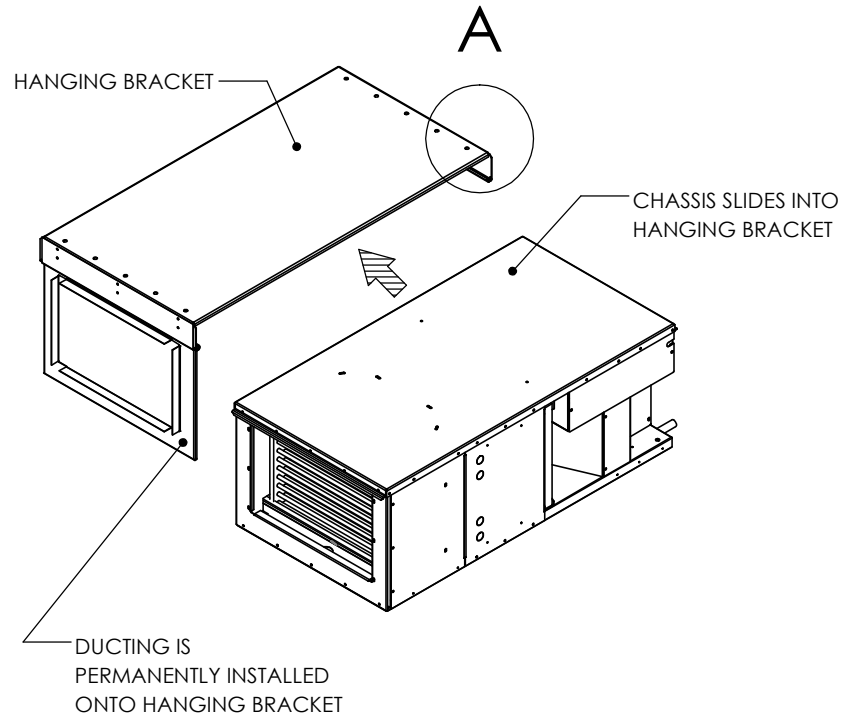

PHYSICAL DATA [in]					MIN. SERVICE CLEARANCE REQUIRED	
W	L	H	SUP. AIR (W x H)	RET. AIR (W x H)	A	B
39	20 1/4	14 1/8	16x10	20x12	6"	20"

THE INFORMATION CONTAINED IN THIS DRAWING IS THE SOLE PROPERTY OF CGC Group. ANY REPRODUCTION IN PART OR AS A WHOLE WITHOUT THE WRITTEN PERMISSION OF CGC Group IS PROHIBITED.



SDW 008-015		
PRODUCT REVISION(S):	L	
DATE(MM/DD/YYYY):	12/01/2025	REV: A
DESCRIPTION:	Standard Submittal Drawing for Sidewinder Horizontal Hybrid R454B	

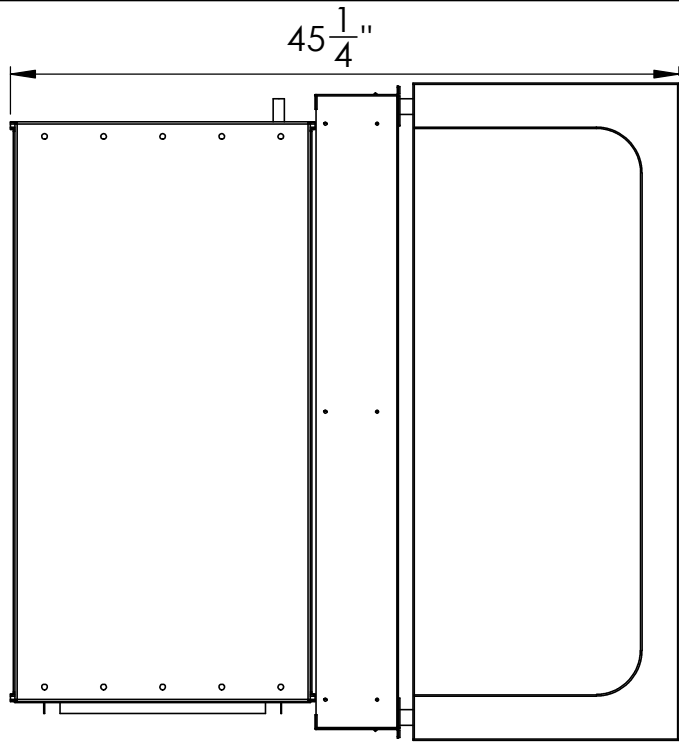

OPEN CABINET

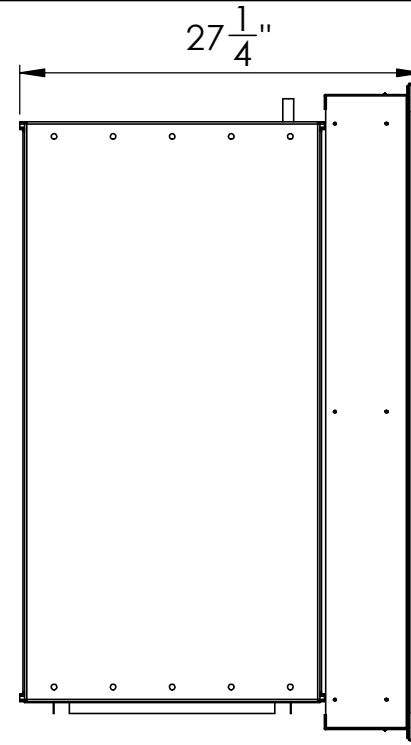

CLOSED CABINET

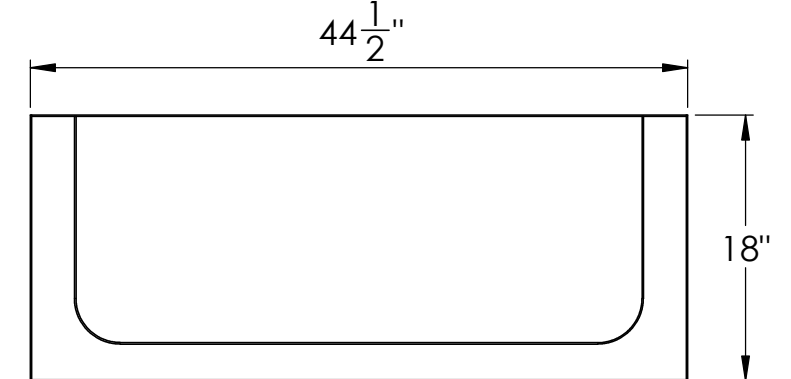
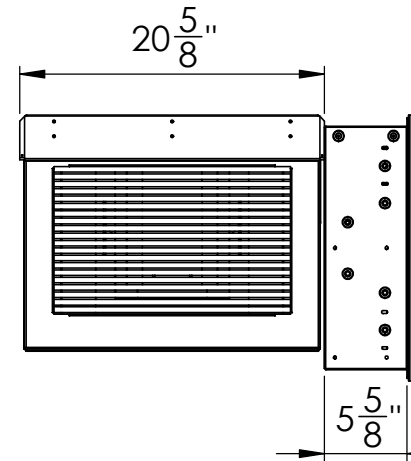
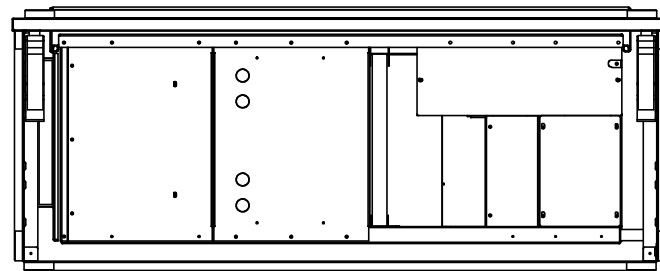
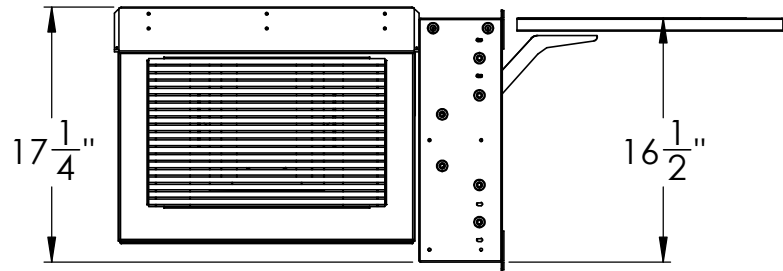

HANGING BRACKET

HINGED PANEL ASSEMBLY

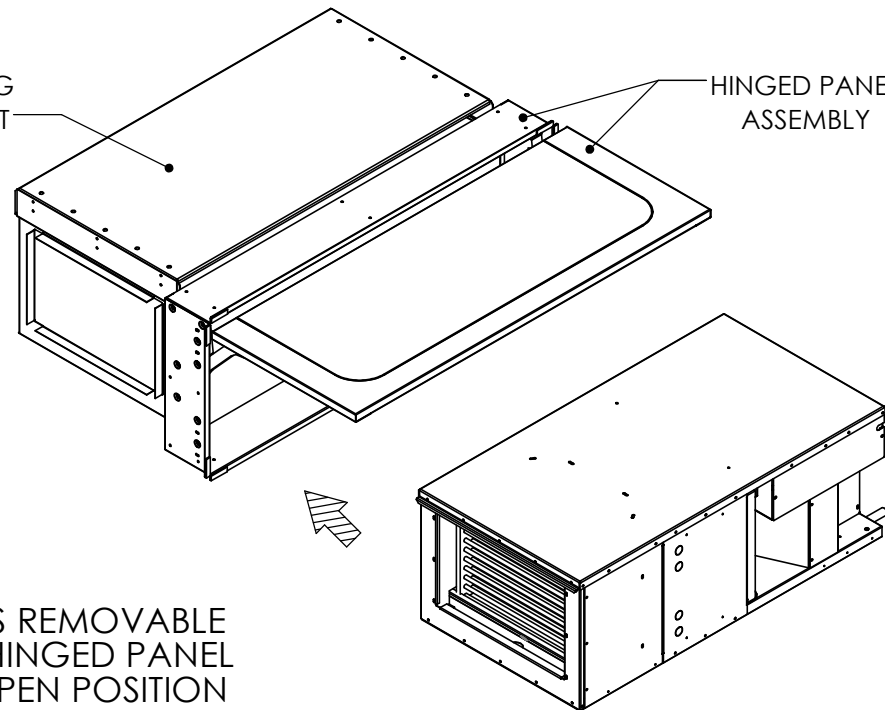

CHASSIS REMOVABLE WHEN HINGED PANEL IS IN OPEN POSITION

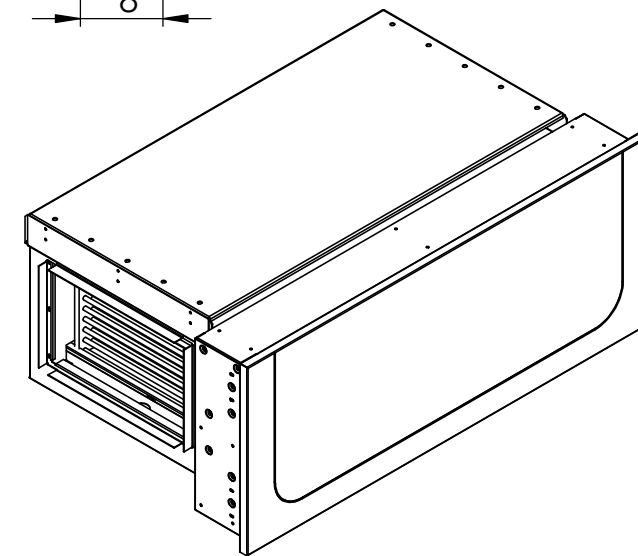

THE INFORMATION CONTAINED IN THIS DRAWING IS THE SOLE PROPERTY OF CGC Group. ANY REPRODUCTION IN PART OR AS A WHOLE WITHOUT THE WRITTEN PERMISSION OF CGC Group IS PROHIBITED.



SDW 008-015

PRODUCT REVISION(S):	All	
DATE(MM/DD/YYYY):	10/27/2025	REV: A
DESCRIPTION:	Standard Submittal Drawing for Sidewinder Horizontal Hybrid R454B	